

PROPER USE GUIDELINES

Cumulative Trauma Disorders can result from the prolonged use of manually powered hand tools. Hand tools are intended for occasional use and low volume applications. A wide selection of powered application equipment for extended-use, production operations is available.

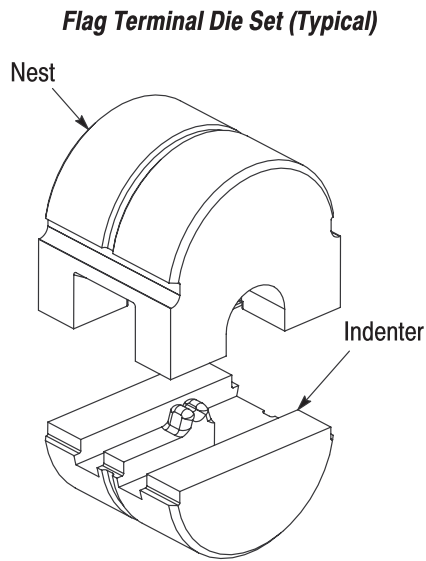

Tools Using Crimping Dies for SOLISTRAND Flag Terminals

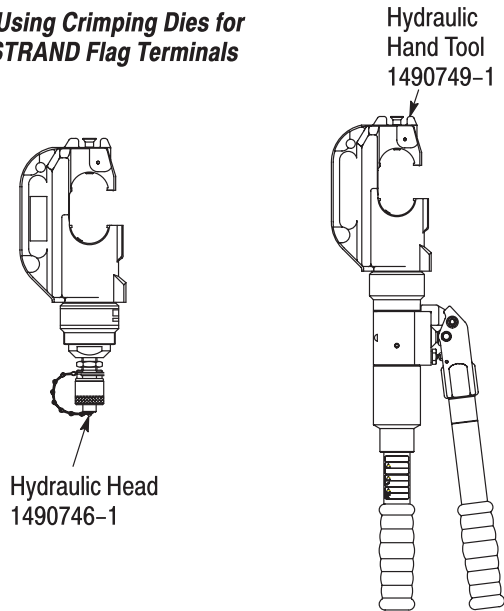

PRODUCT	DIES		NOMINAL WIRE SIZE		MM ² (CMA) RANGE	TOOLING	
	NEST	INDENTER	MM ²	AWG		HYDRAULIC HEAD	HYDRAULIC HAND TOOL
696675-1	1752682-1	1752681-2	7-8	8	6.637-10.539 [13,100-20,800]	1490746-1	1490749-1
696679-1	1752682-2						
322727-[]	1752680-8						
321576	1752680-7	1752681-3	13-15	6	10.539-16.771 [20,800-33,100]		
321060	1752680-6		21	4	16.771-26.653 [33,100-52,600]		
321064	1752680-5		34-35	2	26.653-42.411 [52,600-83,700]		
321066	1752680-4	1752681-1	59-60	1/0	42.411-60.511 [83,700-119,500]		
321584	1752680-3		67-70	2/0	60.551-72.259 [119,500-150,500]		
327887	1752680-2		80-95	3/0	72.259-96.274 [150,500-190,000]		
321259-[]	1752680-1		100-125	4/0	96.274-117.049 [190,000-231,000]		

Figure 1

1. INTRODUCTION

This instruction sheet provides application instructions, maintenance, and inspection procedures for the dies listed in Figure 1. These dies crimp

SOLISTRAND Flag Terminals to solid or stranded copper wire (also listed in Figure 1).

The dies are used in Hydraulic Head 1490746-1 and Hydraulic Hand Tool 1490749-1. Refer to Figure 1.

NOTE

All dimensions on this document are in metric units [with U. S. customary units in brackets]. Figures are for reference only and are not drawn to scale.

2. DESCRIPTION

Each die assembly consists of a nest and an indenter (ordered separately) which are retained in the crimping head by retainer pins. The nest is positioned in the yoke of the crimping head, and the indenter is positioned in the ram of the tool.

3. DIE INSTALLATION AND REMOVAL

Refer to Figure 1 and determine the correct die assembly, wire size, product number, and tool head to use with the die assembly.

CAUTION

Never operate the tool with the dies removed.

3.1. Die Installation (Figure 2)

DANGER

To avoid personal injury, be sure to exercise extreme caution when using the power unit. Avoid depressing the footswitch or trigger control when installing or removing dies.

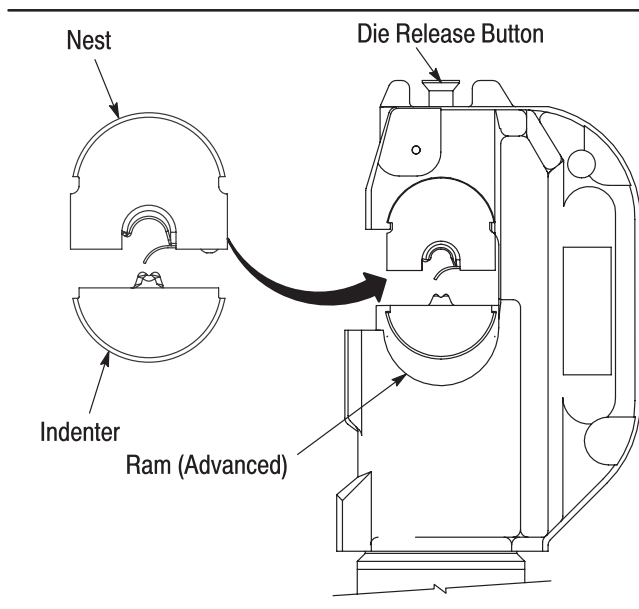

Figure 2

1. Depress the upper release button located in the "C"-head.
2. Slide the nest into place in "C"-head. See Figure 2.
3. Release the button and rock the die back and forth until the nest snaps into position.
4. Activate the power unit until the lower die release button located in the ram is exposed.

5. Depress the release button.
6. Slide the indenter into position in the ram. See Figure 2.
7. Release the button and rock the indenter back and forth until the die snaps into position.
8. Return ram to the down position.

3.2. Die Removal (Figure 2)

1. Depress the upper release button located in the "C"-head and slide the nest out of the head.
2. Activate the power unit until the lower die release button (located in the ram) is exposed.
3. Depress the release button and slide the indenter out of the ram.

4. WIRE STRIPPING AND CRIMPING PROCEDURE

DANGER

AVOID PERSONAL INJURY. Exercise extreme caution when operating crimping head and holding terminals or wire near the crimping dies.

4.1. Wire Stripping

Obtain the correct wire, flag terminal, and crimping tool (with correct die assembly installed) for your application. Strip wire insulation to the dimensions indicated in Figure 3, taking care not to nick or cut conductor(s), and proceed as follows:

4.2. Crimping Procedure

1. Ensure that wire size stamped on flag terminal corresponds to wire size being used in the application and wire size stamped on nest and indenter.
2. Center flag terminal wire barrel in die nest. When crimping flag terminals, hold tongue of flag terminals against nest as shown in Figure 4. If terminal locator is present, slide terminal into terminal locator and press the tongue of the flag terminal against the slope on the nest.
3. Activate power unit so that ram advances and holds terminal in place but DOES NOT deform wire barrel.
4. Insert stripped wire into terminal until end of conductor is flush with or extended slightly beyond end of wire barrel. See Figure 3.
5. Activate power unit to complete crimp.

NOTE

If terminal sticks in die after crimping, grasp wire close to crimp and apply a rocking motion to remove the die.

6. Refer to Paragraph 5.1, Crimp Inspection, for terminal crimp inspection procedure.

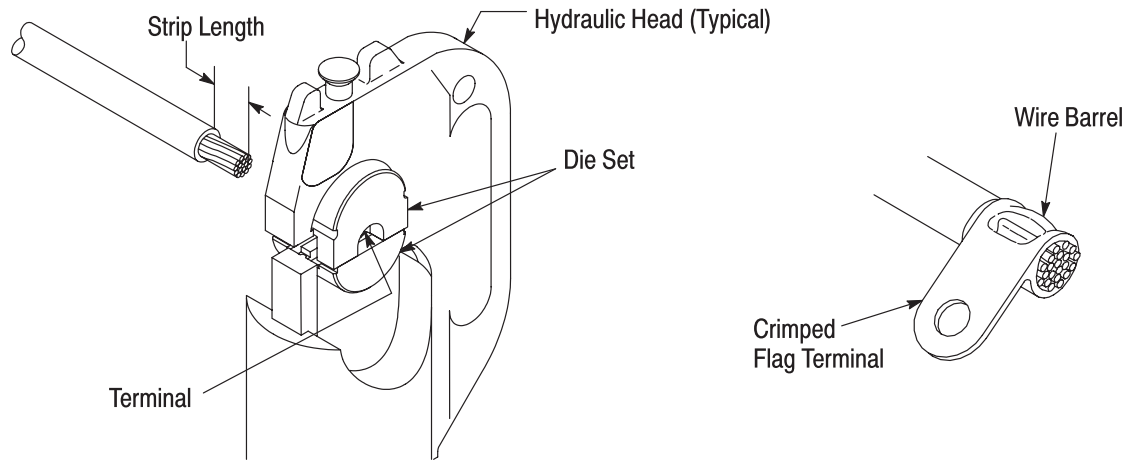

PRODUCT	NOMINAL WIRE SIZE		STRIP LENGTH	
	MM ²	AWG	MINIMUM	MAXIMUM
696775-1	7-8	8	9.53 [.375]	11.18 [.440]
696779-1				
322727-[]				
321576	13-15	6	12.70 [.500]	14.27 [.562]
321060	21	4	13.82 [.554]	15.48 [.609]
321064	34-35	2	17.06 [.672]	18.65 [.734]
321066	59-60	1/0	22.23 [.875]	23.81 [.937]
321584	67-70	2/0	23.81 [.937]	25.40 [1.000]
327887	80-95	3/0	26.98 [1.062]	28.58 [1.125]
321259-[]	100-125	4/0	28.58 [1.125]	30.16 [1.187]

Figure 3

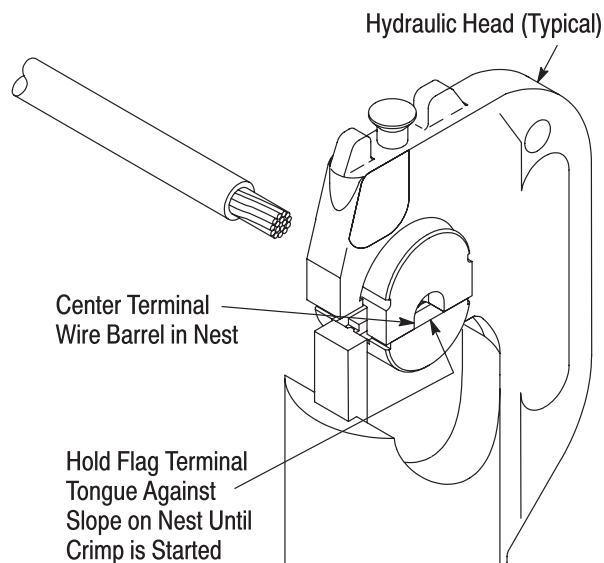

Figure 4

5. MAINTENANCE AND INSPECTION

DANGER

Disconnect power supply before performing maintenance, adjustments, inspections, and repairs.

5.1. Crimp Inspection (Figure 5)

Inspect crimped terminals by checking the features described in Figure 5. Use only terminals that meet the conditions shown in the ACCEPT column. Terminals displaying the features shown in the REJECT column can be avoided by careful use of these instructions and by performing the maintenance and inspection procedures described in Paragraphs 5.2 and 5.3.

5.2. Daily Maintenance

It is recommended that each operator of the dies be made aware of, and responsible for, the following steps of daily maintenance.

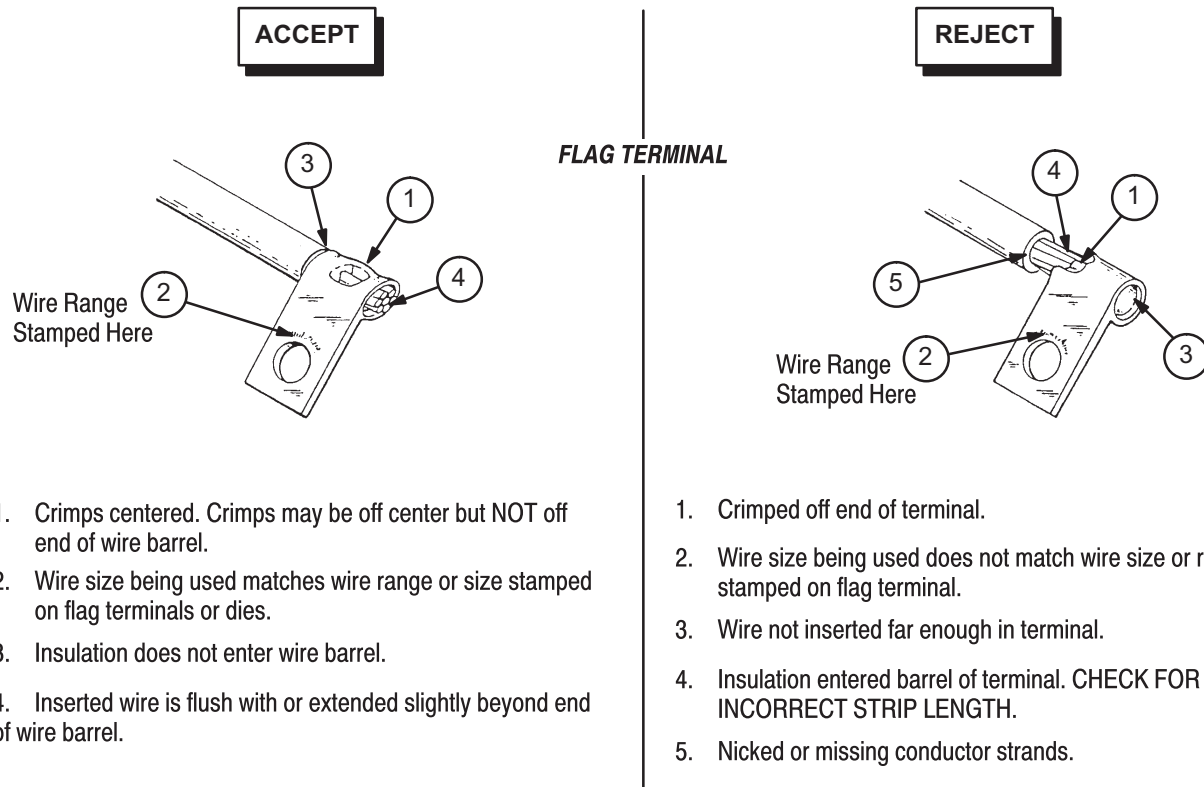

Figure 5

1. Crimps centered. Crimps may be off center but NOT off end of wire barrel.
2. Wire size being used matches wire range or size stamped on flag terminals or dies.
3. Insulation does not enter wire barrel.
4. Inserted wire is flush with or extended slightly beyond end of wire barrel.

1. Crimped off end of terminal.
2. Wire size being used does not match wire size or range stamped on flag terminal.
3. Wire not inserted far enough in terminal.
4. Insulation entered barrel of terminal. CHECK FOR INCORRECT STRIP LENGTH.
5. Nicked or missing conductor strands.

1. Remove dust, moisture, and other contaminants from the dies with a clean brush, or a clean, soft, lint-free cloth. Do NOT use objects that could damage the dies.

2. If dies are coated with oil or preservative, wipe clean – particularly in the crimping areas – before placing them in use.

3. When dies are not in use, make certain all surfaces are protected with a THIN coat of any good SAE No. 20 motor oil, and mate and store them in a clean, dry area.

2. Check all surfaces for wear. Inspect the crimp area for flattened, chipped, cracked, worn, or broken areas. See Figure 6. If damage is evident, the die must be replaced.

5.3. Periodic Inspection

Regular inspections should be performed by quality control personnel. A record of scheduled inspections should remain with the dies or be made available to supervisory personnel responsible for the the dies. Though recommendations call for at least a monthly inspection, the inspection frequency should be based upon the amount of use, working conditions, operator training and skill, and established company standards. These inspections should be performed in the following sequence:

A. Visual Inspection (Figure 6)

1. Remove all lubrication and accumulated film by immersing the dies in a suitable degreaser that will not affect paint or plastic material.

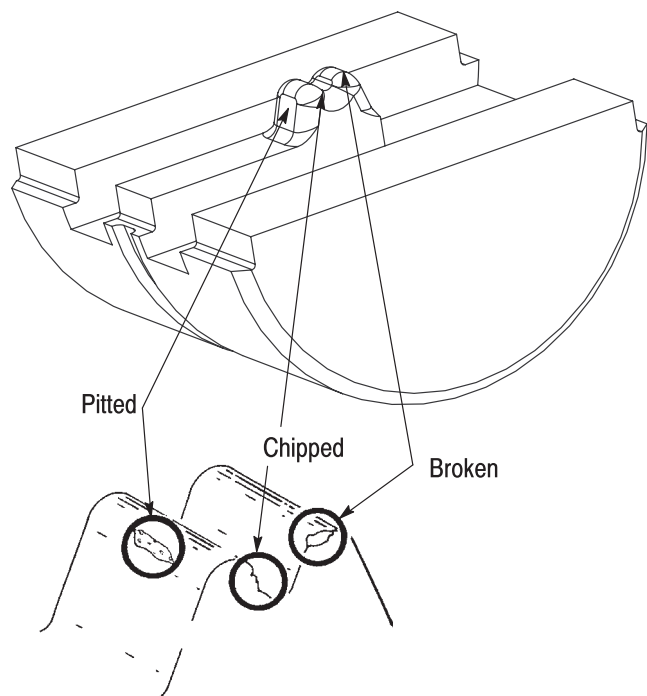

Figure 6

B. Gaging the Crimping Chamber (Figures 7 and 8)

This inspection requires the use of a plug gage conforming to the dimensions in Figure 7. Tyco Electronics does not manufacture or market these gages.

Proceed as follows:

1. Mate the dies until it is evident that they have bottomed. Hold the dies in this position.
2. Align the GO element with the wire barrel crimping chamber. Push the element straight into

the crimping chamber without using force. The GO element must pass completely through the crimping chamber.

3. Align the NO-GO element and try to insert it straight into the same crimping chamber. The NO-GO element may start entry but must not pass completely through. If the crimping chamber conforms to the gage inspection, the dies are considered dimensionally correct. If not, they must be replaced. For additional information regarding the use of a plug gage, refer to Instruction Sheet 408-7424.

Suggested Plug Gage Design

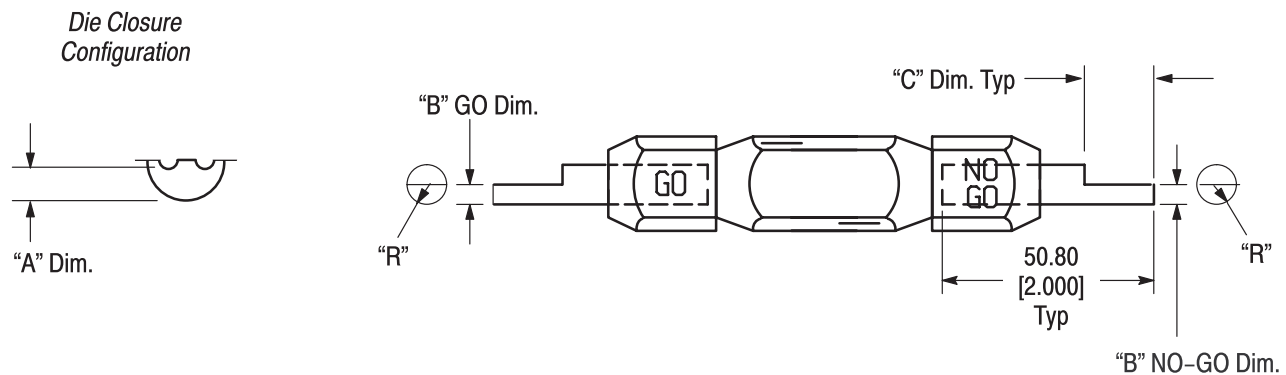

DIES		DIE CLOSURE DIMENSION "A"		GAGE ELEMENT DIMENSION "B"		"C" DIMENSION	RADIUS "R"
NEST	INDENTER	GO	NO-GO	GO	NO-GO		
1752682-1	1752681-2	2.54 [1.000]	2.692 [.1060]	2.54-2.55 [.1000-.1003]	2.689-2.692 [.1059-.1060]	12.70 [.500]	3.58 [.141]
1752682-2							
1752680-8							
1752680-7	1752681-3	3.51 [.1380]	3.708 [.1460]	3.505-3.513 [.1380-.1383]	3.705-3.708 [.1459-.1460]	11.099 [.437]	3.96 [.156]
1752680-6		4.140 [.1630]	4.343 [.1710]	4.140-4.147 [.1630-.1633]	4.340-4.343 [.1709-.1710]		4.76 [.187]
1752680-5		4.953 [.1950]	5.156 [.2030]	4.953-4.960 [.1950-.1953]	5.153-5.156 [.2029-.2030]		5.94 [.234]
1752680-4	1752681-1	6.172 [.2430]	6.375 [.2510]	6.172-6.179 [.2430-.2433]	6.372-6.375 [.2509-.2510]	14.275 [.562]	7.52 [.296]
1752680-3		6.959 [.2740]	7.163 [.2820]	6.959-6.967 [.2740-.2743]	7.160-7.163 [.2819-.2820]		8.33 [.328]
1752680-2		7.823 [.3080]	8.026 [.3160]	7.823-7.830 [.3080-.3083]	8.023-8.026 [.3159-.3160]		9.53 [.375]
1752680-1		8.788 [.3460]	8.991 [.3540]	8.788-8.796 [.3460-.3463]	8.989-8.991 [.3539-.3540]		10.89 [.421]

Figure 7

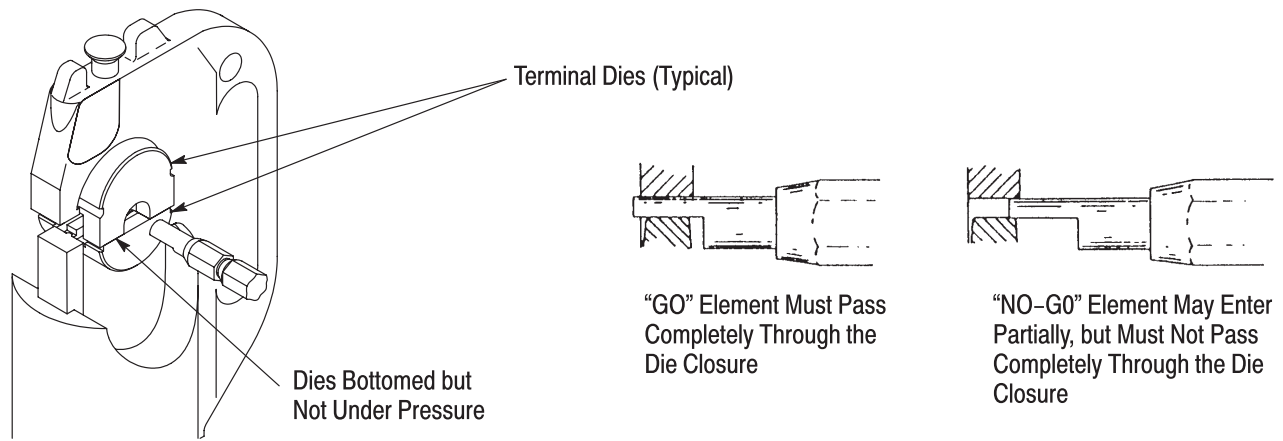

Figure 8

6. REPLACEMENT PARTS

Refer to Figure 1 when replacement of a die becomes necessary, contact your local Tyco Electronics Representative; call 1-800-526-5142; send a facsimile of your purchase order to 1-717-986-7605; or write to:

CUSTOMER SERVICE (38-35)
TYCO ELECTRONICS CORPORATION
P. O. BOX 3608
HARRISBURG, PA 17105-3608

7. REVISION SUMMARY

Per EC 0990-0402-04:

- Initial release of instruction sheet