

PROPER USE GUIDELINES

Cumulative Trauma Disorders can result from the prolonged use of manually powered hand tools. Hand tools are intended for occasional use and low volume applications. A wide selection of powered application equipment for extended-use, production operations is available.

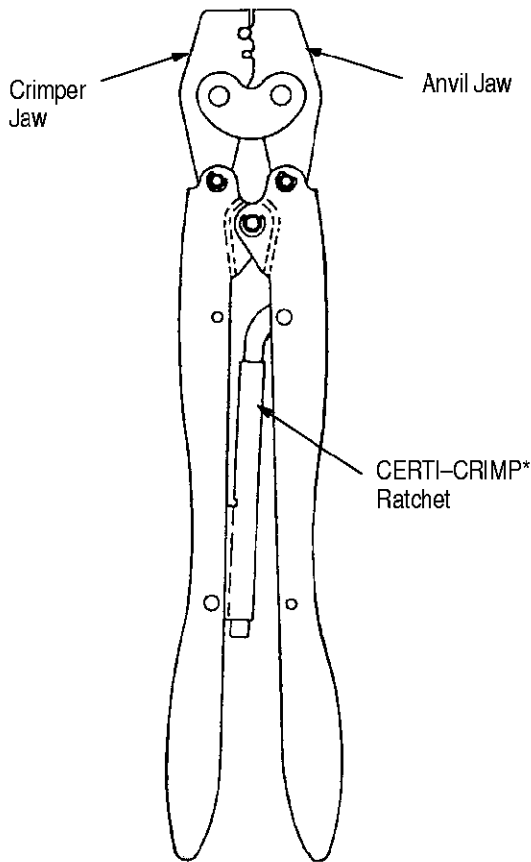

Figure 1

1. INTRODUCTION

This instruction sheet covers the use of Hand Crimping Tool 69478-1 (see Figure 1) which is used to crimp COAXICON* RF plug and jack type connectors shown in Figure 2. Read these instructions thoroughly before using the tool.

NOTE

Dimensions on this sheet are in millimeters [with inches in brackets].

Reasons for reissue are provided in Section 6, REVISION SUMMARY.

2. DESCRIPTION

The tool (shown in Figure 1) features two sets of crimping dies (contained within the crimper and anvil jaws), a center contact locator, and a CERTI-CRIMP ratchet.

One set of crimping dies is used to crimp the ferrule and the other set is used to crimp the center contact.

The center contact locator aids in positioning the center contact in the crimping dies.

The CERTI-CRIMP ratchet assures full crimping of the contacts and ferrules. Once engaged, the ratchet will not release until the handles have FULLY closed.

CAUTION

The crimping dies bottom before the CERTI-CRIMP ratchet releases. This design feature assures maximum electrical and tensile performance of the crimp. Do NOT re-adjust the ratchet.

Typical BNC Plug-Type Connector Assembly●

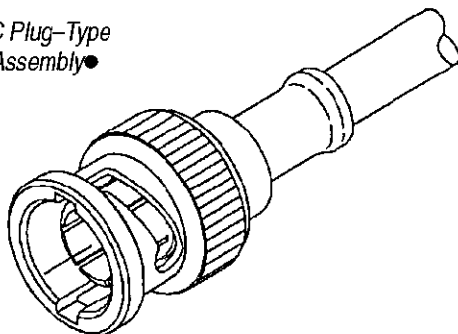

Typical BNC Jack-Type Connector Assembly●

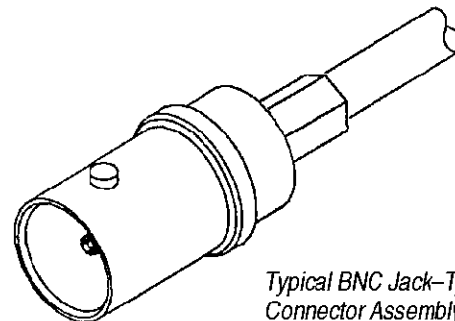

● For applicable connector part numbers, refer to Catalog 82074.

Figure 2

3. CRIMPING PROCEDURE

NOTE Each hand tool is coated with a preservative to prevent rust or corrosion. Wipe this preservative from the tool, particularly from the crimping jaws, before using the tool.

These procedures provide instructions on the use of the hand tool for crimping only. For information pertaining to the individual connectors, such as cable stripping dimensions and assembly of component parts, refer to instruction sheets 408-1914-1 (for plug-type connectors) and 408-1914-2 (for jack-type connectors). The crimping procedure requires two separate crimps. First, the center contact assembly must be crimped to the center conductor of the cable; then the ferrule is crimped to the cable and connector.

3.1. Crimping Center Contact

Refer to Figure 3 and proceed as follows:

1. Slip ferrule on cable, then strip cable to appropriate dimensions.
2. Open the tool's jaws by squeezing the handles until the ratchet releases and then allow the handles to open FULLY.
3. Insert the center contact into the locator, as shown in Figure 3.
4. Slowly close tool handles until the contact is held firmly in place. Do NOT deform the wire barrel of the center contact.
5. Insert center conductor of cable into contact wire barrel until cable dielectric butts against contact.

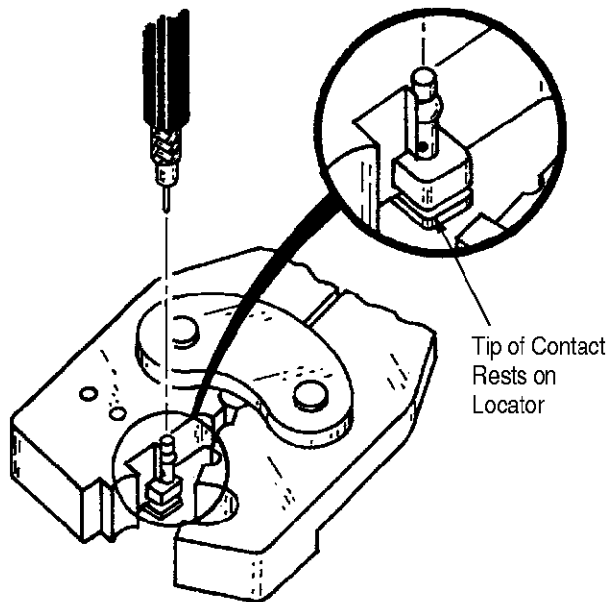

Figure 3

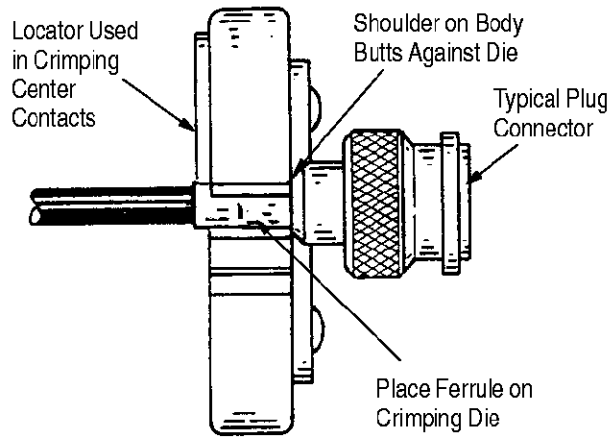

Figure 4

6. While holding cable in place, close tool handles until ratchet releases. Allow handles to open and remove crimped contact assembly.

3.2. Crimping Ferrule

Refer to Figure 4 and proceed as follows:

1. Flair the cable braid.
2. Assemble the connector body over the crimped center contact, making sure the cable braid is over the support sleeve of the connector body.
3. Slide ferrule over braid and support sleeve until it is against the connector body.
4. Open the tool's jaws by squeezing the handles until the ratchet releases and then allow the handles to open FULLY.
5. Position the plug or jack connector assembly into the ferrule crimping area of the tool.
6. To complete crimp, close handles until ratchet releases. Allow handles to open and remove crimped connector assembly.

CAUTION Damaged contacts or ferrules must be removed and replaced with new ones.

4. MAINTENANCE AND INSPECTION PROCEDURE

Tyco Electronics recommends that a maintenance and inspection program be performed periodically to ensure dependable and uniform terminations. Frequency of inspection depends on:

1. The care, amount of use, and handling of the hand tool.
2. The presence of abnormal amounts of dust and dirt.
3. The degree of operator skill.
4. Your own established standards.

The hand tool is inspected before being shipped; however, Tyco Electronics recommends that the tool be inspected immediately upon its arrival at your facility to ensure that the tool has not been damaged during shipment. Due to the precision design, it is important that no parts of these tools be interchanged except those replacement parts listed in Figure 8.

4.1. Daily Maintenance

1. Remove dust, moisture, and other contaminants with a clean brush, or a soft, lint-free cloth. Do NOT use objects that could damage the tool.
2. Make certain that the retaining pins are in place and that they are secured with retaining rings.
3. All pins, pivot points, and bearing surfaces should be protected with a thin coat of any good SAE 20 motor oil. Do not oil excessively.
4. When the tool is not in use, keep handles closed to prevent objects from becoming lodged in the crimping dies. Store the tool in a clean, dry area.

4.2. Lubrication

Lubricate all pins, pivot points, and bearing surfaces with SAE 20 motor oil as follows:

- Tools used in daily production – lubricate daily
- Tools used daily (occasional) – lubricate weekly
- Tools used weekly – lubricate monthly

Wipe excess oil from tool, particularly from crimping area. Oil transferred from the crimping area onto certain terminations may affect the electrical characteristics of an application.

4.3. Periodic Inspection

1. Hand tool should be immersed (handles partially closed) in a reliable commercial degreasing compound to remove accumulated dirt, grease, and foreign matter.
2. Close tool handles until ratchet releases and then allow them to open freely. If they do not open quickly and fully, the spring is defective and must be replaced. See Section 5, REPLACEMENT AND REPAIR.
3. Inspect head assembly for worn, cracked, or broken dies. If damage is evident, return the tool to Tyco Electronics for evaluation and repair. See Section 5, REPLACEMENT AND REPAIR.

4.4. Crimping Die Closure Inspections

A. Ferrule Die Closure Inspection

This inspection requires the use of a plug gage conforming to the dimensions shown in Figure 5. Tyco Electronics does not manufacture or market this gage.

SUGGESTED PLUG GAGE DESIGN – FERRULE DIES

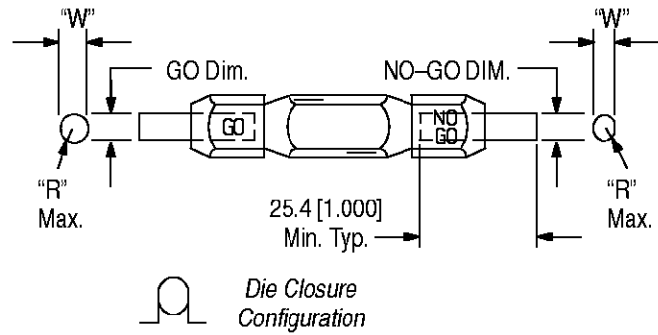

TOOL NUMBER	GAGE ELEMENT DIMENSIONS			
	GO	NO-GO	"W" MAX.	RADIUS "R" (MAX.)
69478-1	5.46-5.47 [.2150-.2153]	5.611-5.613 [.2209-.2210]	5.33 [.210]	2.67 [.105]

Figure 5

To gage die closure, refer to Figure 6 and proceed as follows:

1. Remove traces of oil or dirt from the crimping chamber and plug gage.
2. Close the tool handles until it is evident that the jaws have bottomed; then hold in this position. Do NOT force the jaws beyond initial contact.
3. Align the GO element of the plug gage with the ferrule crimping chamber. Push element straight into the crimping chamber without using force. The GO element must pass completely through the crimping chamber.
4. Check the ferrule crimping chamber with the NO-GO element in the same manner as step 3. The NO-GO element may start entry, but must not pass completely through the crimping chamber.

If die closure conforms to the gage inspection, the crimping chamber is considered dimensionally correct. If not correct, the tool must be returned to Tyco Electronics for further evaluation and repair. Refer to Section 5, REPLACEMENT AND REPAIR. For additional information regarding the use of a plug gage, refer to instruction sheet 408-7424.

B. Center Contact Crimp Height Inspection

This inspection requires the use of micrometer with a modified anvil as shown in Figure 7. Tyco Electronics recommends use of the modified micrometer (Crimp Height Comparator RS-1019-5LP) which can be purchased from:

Shearer Industrial Supply Co. or VALCO
717-767-7575 610-691-3205

Inspection of Ferrule Die Closure

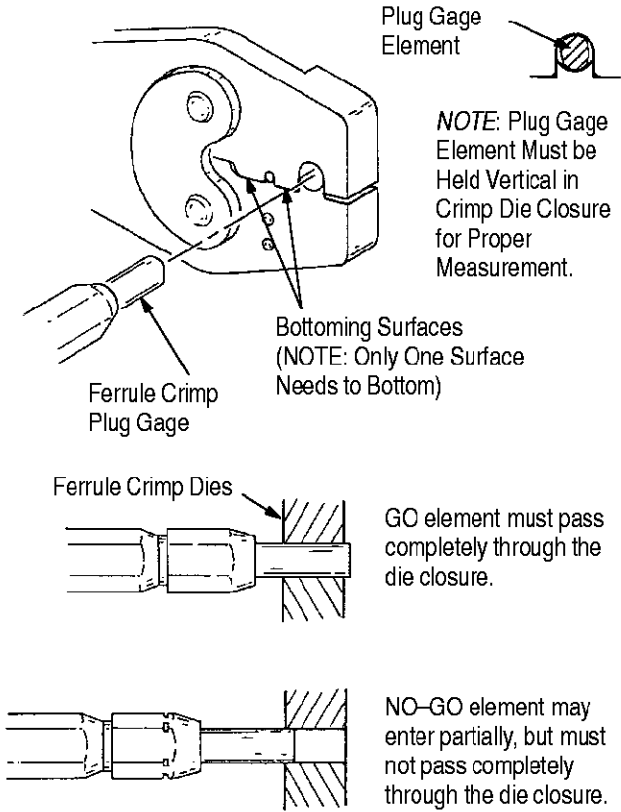

Figure 6

Proceed as follows:

1. Select an appropriate center contact and cable.
2. Refer to Paragraph 3.1, Crimping Center Contact, and crimp a test center contact.
3. Using a crimp height comparator, measure wire barrel crimp height as shown in Figure 7. If the crimp height conforms to that shown in the chart, the tool is considered dimensionally correct. If not, return the tool to Tyco Electronics for evaluation and repair (refer to Section 5, REPLACEMENT AND REPAIR).

For additional information concerning the use of the crimp height comparator, refer to instruction sheet 408-7424.

4.5. CERTI-CRIMP Ratchet Inspection

The CERTI-CRIMP ratchet feature on the hand tools should be checked to ensure that the ratchet does not release prematurely, allowing the crimping dies to open before they have fully bottomed. Obtain a 0.025-mm [.001-in.] shim that is suitable for checking the clearance between the bottoming surfaces of the crimping dies. Proceed as follows:

1. Assemble an appropriate center contact assembly and cable.
2. Position the center contact assembly and cable between the crimping dies, as described in Paragraph 3.1, Crimping Center Contact.
3. Hold the center contact assembly and cable in place and squeeze the handles until the CERTI-CRIMP ratchet releases. Hold the handles in this position, maintaining just enough tension to keep the dies closed.
4. Check the clearance between the bottoming surfaces of the crimping dies. If the clearance is 0.025 mm [.001 in.] or less, the ratchet is satisfactory. If clearance exceeds 0.025 mm [.001 in.], the ratchet is out of adjustment and must be repaired. See Section 5, REPLACEMENT AND REPAIR.

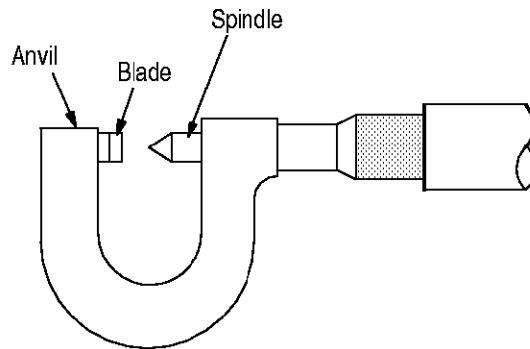
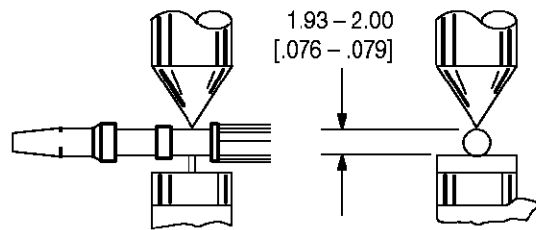

Figure 7

5. REPLACEMENT AND REPAIR

Replacement parts are listed in Figure 8. Parts other than those listed in Figure 8 should be replaced by Tyco Electronics to ensure quality and reliability of the tool. Order replacement parts through your Tyco Electronics Representative, or call 1-800-526-5142, or send a facsimile of your purchase order to 1-717-986-7605, or write to:

CUSTOMER SERVICE (38-35)
TYCO ELECTRONICS CORPORATION
P.O. BOX 3608
HARRISBURG, PA 17105-3608

For tool repair service, please contact a Tyco Electronics Representative at 1-800-526-5136.

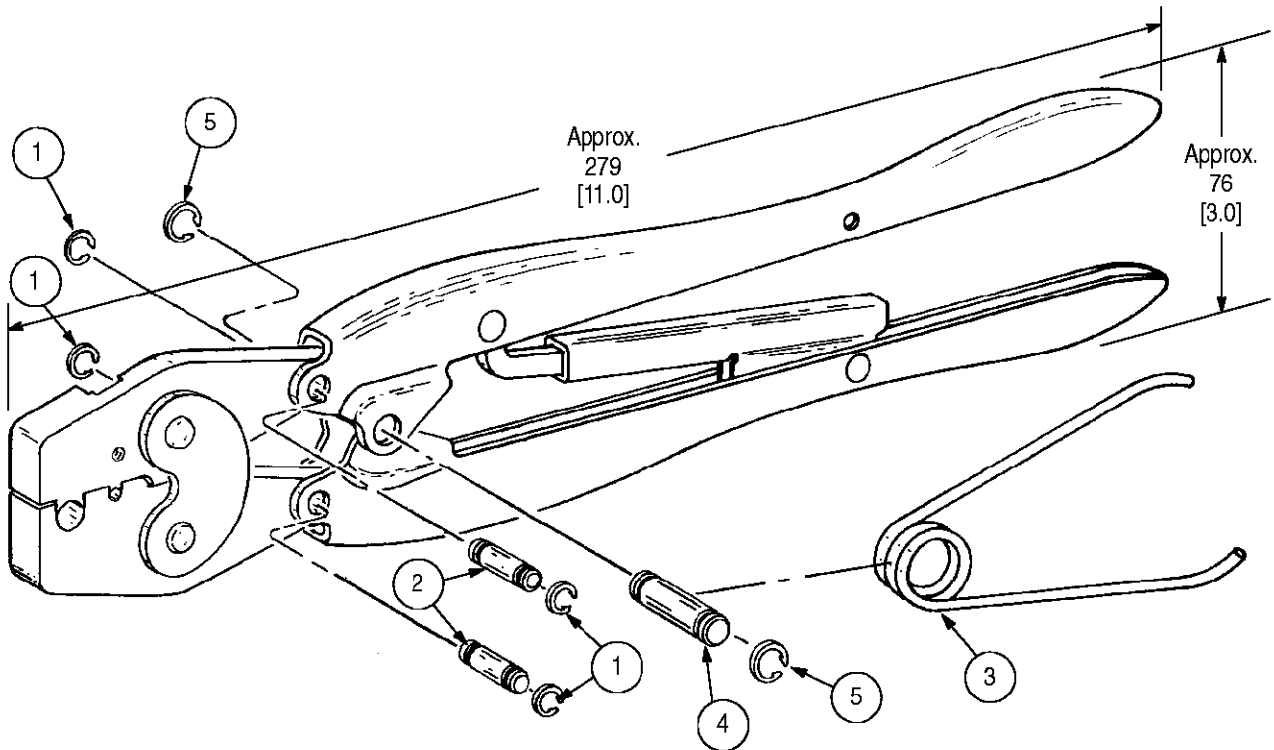

REPLACEMENT PARTS			
ITEM	PART NUMBER	DESCRIPTION	QTY PER ASSY
1	21045-3	RING, Retaining	4
2	1-23619-6	PIN, Retaining	2
3	39364	SPRING	1
4	2-23620-9	PIN, Retaining	1
5	21045-6	RING, Retaining	2

Figure 8

6. REVISION SUMMARY

Since the previous release of this sheet, the following changes were made:

Per EC 0990-0645-02

- Updated document to corporate requirements
- Changed tool artwork to show gap in front of tool