

PROPER USE GUIDELINES

Cumulative Trauma Disorders can result from the prolonged use of manually powered hand tools. Hand tools are intended for occasional use and low volume applications. A wide selection of powered application equipment for extended-use, production operations is available.

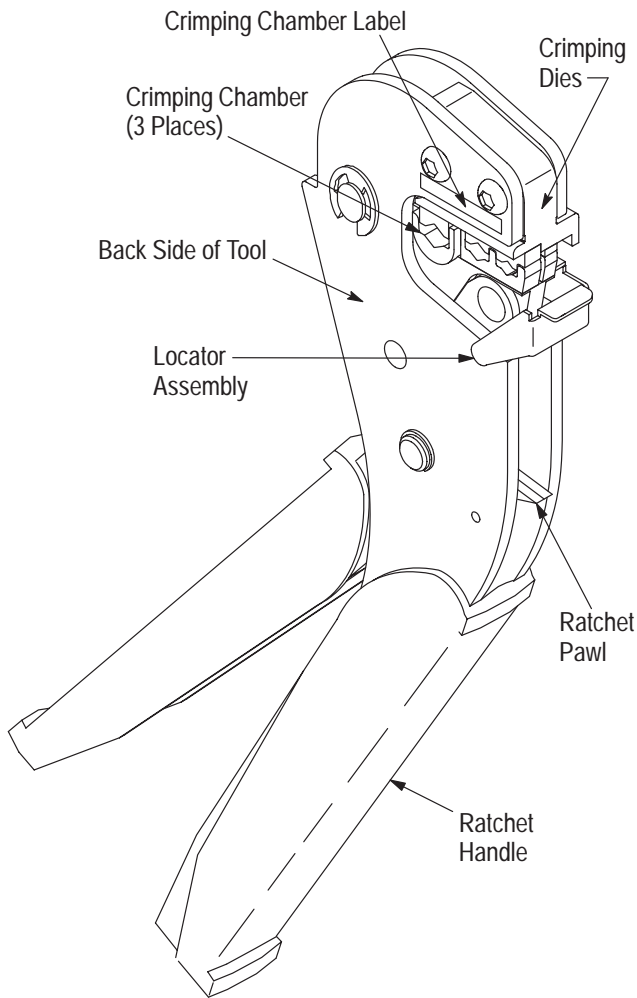

Figure 1

1. INTRODUCTION

TETRA-CRIMP Hand Crimping Tool 59824-1 (shown in Figure 1) is designed to crimp the terminals and splices listed in Figure 2 onto stranded wire sizes 22 through 10 AWG. Refer to Catalog 82042 for product part numbers. Read these instructions thoroughly before using the hand tool.

NOTE *Dimensions in this instruction sheet are in millimeters [with inches in brackets]. Figures are for reference only and are not drawn to scale.*

Reasons for reissue are provided in Section 7, REVISION SUMMARY.

2. DESCRIPTION

Each hand tool features two crimping dies, a spring-loaded locator assembly, and a ratchet handle with a ratchet pawl. See Figure 1. When closed, the dies form three crimping chambers each labeled by color on the BACK side of the tool. The color indicates the wire size and must match the insulation color of the terminal or splice: yellow (12-10), blue (16-14), red (22-16), black heavy duty (16-14 HD), and green (20-16 HD).

The locator assembly positions the terminal or splice between the crimping dies. The ratchet handle assures full crimping. Once engaged, the ratchet will not release until the tool handles have been FULLY closed, unless the ratchet pawl is depressed to manually release the ratchet. This feature, when depressed, prevents crimping of an improperly positioned terminal or splice.



CAUTION

The crimping dies bottom before the ratchet releases. This feature assures maximum electrical and tensile performance of the crimp. Do NOT re-adjust the ratchet.

3. CRIMPING PROCEDURE

Select the appropriate wire size and terminal or splice for the hand tool. The wire size and insulation diameter must be within the specified range for the terminal or splice. Strip the wire to the dimension provided in Figure 2. Do NOT nick or cut the wire strands. Then, proceed as follows:

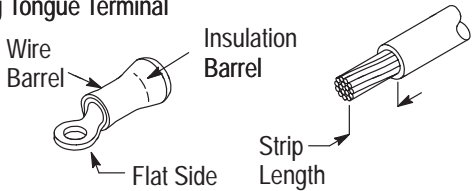
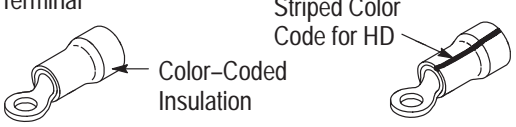
1. Open the crimping dies by squeezing the tool handles together until the ratchet releases.
2. Push the locator assembly away from the upper crimping die slightly and hold.
 - a. If crimping a terminal, position the wire barrel in the appropriate crimping chamber between the locator assembly and the upper die. Make sure that the flat side of the terminal faces up. See Figure 3, Detail A.
 - b. If crimping a splice, position the wire barrel in the appropriate crimping chamber. Seat the splice window indent on the locator assembly. Refer to Figure 3, Detail B.
3. Holding the wire barrel in place, release the locator assembly.
4. Hold the tool so that the BACK side is facing you, and insert the stripped wire into wire barrel until the wire bottoms. Refer to Figure 3.

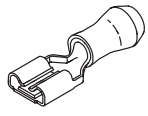
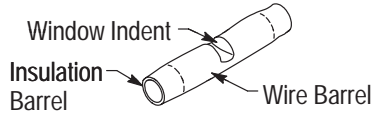
| TERMINAL OR SPLICE | WIRE | | | CRIMP DOT CODE (After Crimping) | |
|---|------------|---------------------------------|--------------------------------------|------------------------------------|---|
| | SIZE (AWG) | INSULATION DIAMETER RANGE | STRIP LENGTH ±0.397 [±.016] | | |
| PIDG* (Pre-Insulated Diamond Grip) Ring Tongue Terminal  | 22-16 | 2.03-3.56 [.080-.140] | 5.56 [.219] | 1 | |
| | 16-14 | 2.67-4.32 [.105-.170] | | 2 | |
| | 12-10 | 3.81-6.35 [.150-.250] | 8.33 [.328] | 1 | |
| | 16-14 HD | 3.81-6.35 [.150-.250] | | 1 | |
| PLASTI-GRIP* Ring Tongue Terminal  | 22-16 | 2.03-3.56 [.080-.140] | 5.56 [.219] | 1 | |
| | 16-14 | 2.67-4.32 [.105-.170] | | 2 | |
| | 12-10 | 3.81-6.35 [.150-.250] | 8.33 [.328] | 1 | |
| | 16-14 HD | 2.67-6.35 [.105-.250] | | 1 | |
| PIDG Insulation Restriction Ring Tongue Terminal  | 22 | 0.97-2.79 [.038-.110] | 6.75 [.266] | 1 | |
| | 20 | 1.17-2.79 [.046-.110] | | 1 | |
| | 18 | 1.42-2.79 [.056-.110] | | 1 | |
| | 16 | 1.60-3.30 [.063-.130] | | 2 | |
| | 14 | 1.98-3.30 [.078-.130] | | 2 | |
| | 12 | 2.41-5.08 [.095-.200] | | 9.92 [.391] | 1 |
| | 10 | 3.02-5.08 [.119-.200] | | | 1 |
| PIDG FASTON* Terminal  | 22-18 | 2.67-3.56 [.105-.140] | 7.94 [.313] | 1 | |
| | 16-14 | 2.92-4.32 [.115-.170] | | 2 | |
| | 12-10 | 3.81-6.35 [.150-.250] | 8.73 [.344] | 1 | |
| PIDG Butt Splice  | 22-16 | 2.03-3.18 [.080-.125] | 6.75 [.266] | 1 | |
| | 16-14 | 2.67-3.81 [.105-.150] | | 2 | |
| | 12-10 | 4.32-5.59 [.170-.220] | 9.13 [.359] | 1 | |

Tools with Revision AA and later do not have crimp dot codes.

Figure 2

5. Holding the wire in place, squeeze the tool handles together until the ratchet releases. Allow the tool handles to open FULLY.
6. Remove crimped terminal or splice from the tool.
7. If crimping a splice, position the uncrimped wire barrel in the crimping chamber. Make sure to seat the splice window indent on the locator assembly. Repeat Steps 3 through 6.

CAUTION *Damaged or worn terminals must not be used. Terminals may be removed from the wire, discarded, and replaced with new ones.*

4. CRIMP INSPECTION

- Check that the crimp dot code on the color-coded insulation indicates the crimping chamber used. Refer to Figure 2.
- Check that the crimp is centered on the wire barrel. See Figure 4.
- Make sure that the wire insulation does not enter the wire barrel. See Figure 4.
- Check that the wire end is flush with or slightly beyond the end of the wire barrel. See Figure 4.

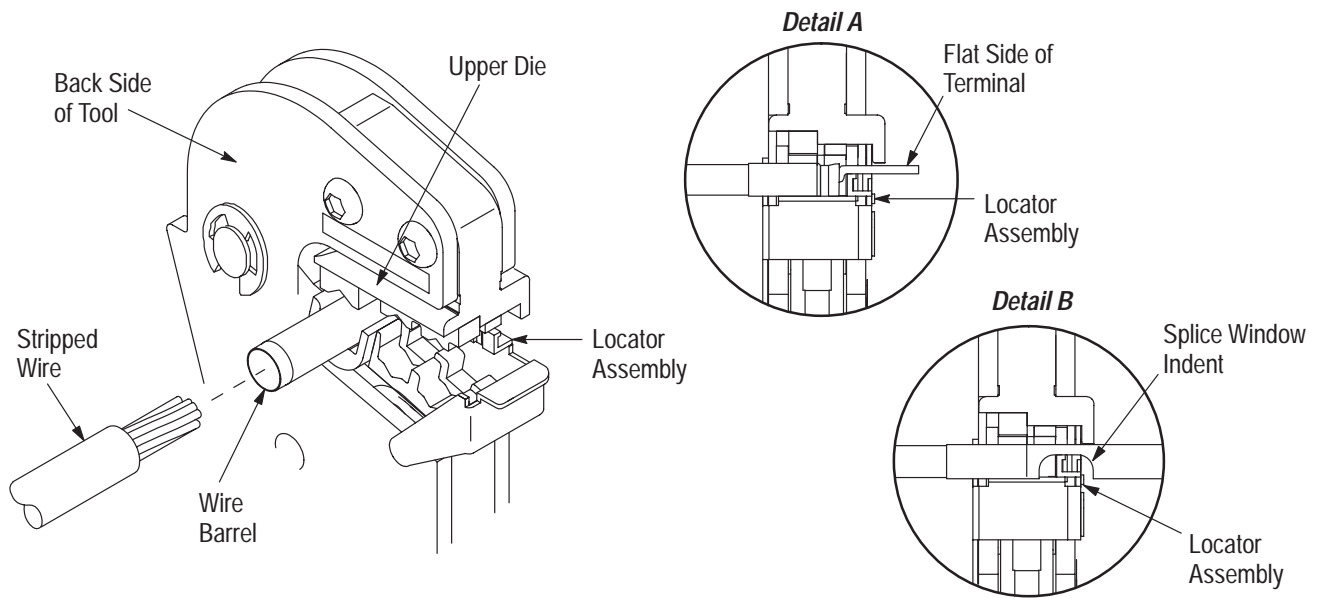

Figure 3

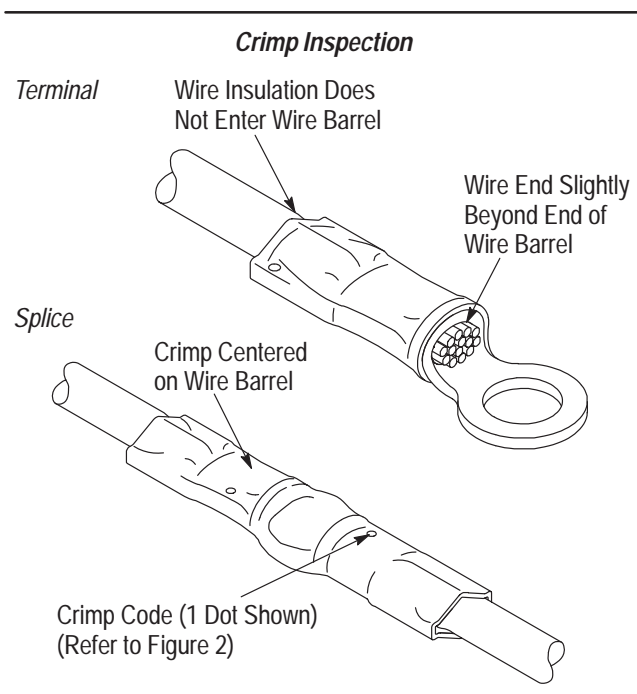

Figure 4

5. MAINTENANCE AND INSPECTION

It is recommended that a maintenance and inspection program be performed periodically to ensure dependable and uniform terminations. Though recommendations call for at least one inspection a month, frequency of inspection depends upon the following:

1. The care, amount of use, and handling of the hand tool.

2. The presence of abnormal amounts of dust and dirt.
3. The degree of operator skill.
4. Your own established standards.

The hand tool is inspected before being shipped; however, it is recommended that the tool be inspected immediately upon arrival at your facility to ensure that the tool has not been damaged during shipment.

5.1. Daily Maintenance

1. The hand tool should be immersed (handles partially closed) in a reliable commercial degreasing compound to remove accumulated dirt, grease, and foreign matter. When degreasing compound is not available, tool may be wiped clean with a soft, lint-free cloth. Do NOT use hard or abrasive objects that could damage the tool.
2. Make certain that the retaining pins are in place and that they are secured with retaining rings.
3. All pins, pivot points, and bearing surfaces should be protected with a THIN coat of any good SAE 20 motor oil. Do NOT oil excessively.
4. When the tool is not in use, keep handles closed to prevent objects from becoming lodged in the crimping dies. Store the tool in a clean, dry area.

5.2. Periodic Inspection

A. Lubrication

Lubricate all pins, pivot points, and bearing surfaces with SAE 20 motor oil as follows:

- Tool used in daily production—lubricate daily
- Tool used daily (occasional)—lubricate weekly
- Tool used weekly—lubricate monthly

Wipe excess oil from tool, particularly from crimping area. Oil transferred from the crimping area onto certain terminations may affect the electrical characteristics of an application.

B. Visual Inspection

1. Close tool handles until ratchet releases and then allow them to open freely. If they do not open quickly and fully, the spring is defective and must be replaced. See Section 6, REPLACEMENT AND REPAIR.
2. Inspect crimping area for worn, cracked, or broken dies. If damage is evident, return the tool for evaluation and repair. See Section 6, REPLACEMENT AND REPAIR.

C. Ratchet Inspection

The ratchet feature on these hand tools should be checked to ensure that the ratchet does not release prematurely, allowing the dies to open before they have fully bottomed.

1. Squeeze the tool handles together, and count the number of ratchet stops. Five stops, including the release position, should be indicated by the movement of the ratchet pawl and the clicking sound associated with its movement. Refer to Figure 1.
2. If fewer positions are indicated, the ratchet pawl and ratchet handle must be replaced. Refer to Section 6, REPLACEMENT AND REPAIR.
3. If dies do not bottom after 5 ratchet stops, return tool for repair. Refer to Section 6, REPLACEMENT AND REPAIR.

When the tool passes the ratchet inspection, lubricate it with a THIN coat of any good SAE 20 motor oil.

D. Gaging the Crimping Chamber

This inspection requires the use of a plug gage conforming to the dimensions provided in Figure 5. To gage the crimping chamber, proceed as follows:

1. Remove traces of oil or dirt from the crimping chamber and plug gage.
2. In order to properly gage this tool, a terminal must be crimped in the crimping chamber being inspected. In place of a terminal, a soft material such as brass or solder may be used to seat the tooling.
3. Close the tool handles until the crimping dies have bottomed; then hold in this position. DO NOT force the dies beyond initial contact.

Suggested Plug Gage Design

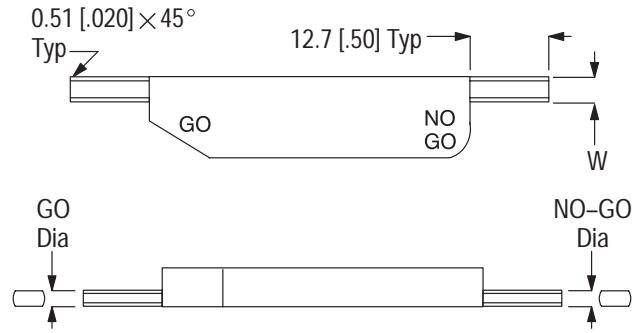

Inspection of Crimping Chamber

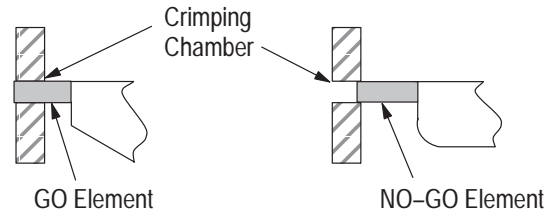

GO element must pass completely through the crimping chamber.

NO-GO element may enter partially, but must not pass completely through the crimping chamber.

| CRIMPING CHAMBER COLOR CODE | GAGE ELEMENT DIAMETER | | "W" (Width) Max |
|-----------------------------|------------------------------|------------------------------|-----------------|
| | GO | NO-GO | |
| Red | 1.981-1.988 [.0780-.0783] | 2.181-2.184 [.0859-.0860] | 4.69 [.185] |
| Blue/Green | 2.336-2.344 [.0920-.0923] | 2.537-2.540 [.0999-.1000] | 5.33 [.210] |
| Yellow/Black | 3.251-3.258 [.1280-.1283] | 3.451-3.454 [.1359-.1360] | 6.85 [.270] |

Figure 5

4. Hold locator assembly away from crimping dies. Carefully insert GO element into the corresponding crimping chamber; do not force it. The GO element must pass completely through the crimping chamber.
5. In the same manner, try to insert the NO-GO element into the same crimping chamber. The NO-GO element may start entry, but must not pass completely through the crimping chamber. See Figure 5.

If the crimping chambers conform to the crimping chamber inspection, the tool is considered dimensionally correct, and should be lubricated with a THIN coat of any good SAE 20 motor oil. If not, return the tool for further evaluation and repair. Refer to Section 6, REPLACEMENT AND REPAIR.

For additional information concerning the use of a plug gage, refer to instruction sheet 408-7424.

Order replacement parts through your representative, or call 1-800-526-5142, or send a facsimile of your purchase order to 717-986-7605, or write to:

6. REPLACEMENT AND REPAIR

Customer-replaceable parts are listed in Figure 6. A complete inventory should be stocked and controlled to prevent lost time when replacement of parts is necessary. Parts other than those listed should be replaced to ensure quality and reliability.

CUSTOMER SERVICE (038-035)
TYCO ELECTRONICS CORPORATION
PO BOX 3608
HARRISBURG PA 17105-3608

For customer repair service, please contact a representative at 1-800-526-5136.

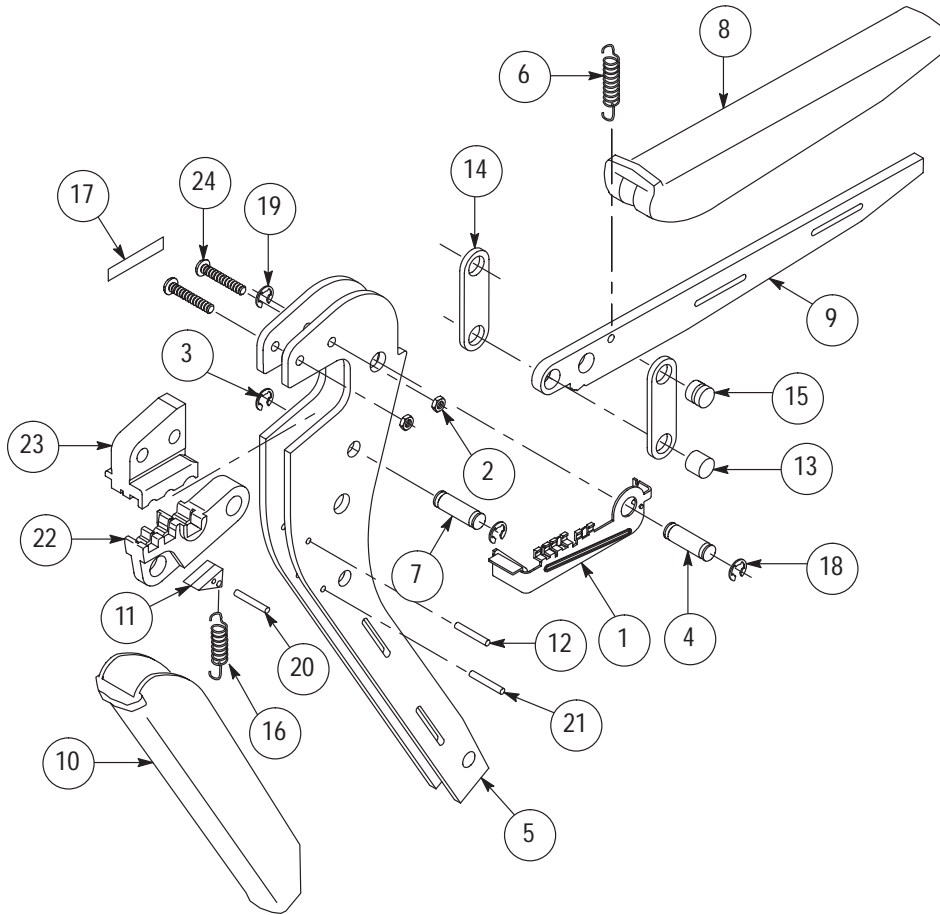

REPLACEMENT PARTS

| ITEM | PART NUMBER | DESCRIPTION | QTY PER TOOL |
|------|-------------|-------------------------|--------------|
| 1 | 310581-1 | STOP, Terminal and Wire | 1 |
| 2 | 21018-6 | NUT, 8-32 | 2 |
| 3 | 1-21116-0 | RING, Retaining | 2 |
| 4 | 7-59558-9 | PIN, Jaw, Pivot | 1 |
| 5 | 354098-2 | FRAME, Subassembly | 1 |
| 6 | 354266-1 | SPRING, Extension | 1 |
| 7 | 7-59558-8 | PIN, Handle, Retaining | 1 |
| 8 | 310575-1 | HANDLE, Plastic | 1 |

Figure 6 (cont'd)

| REPLACEMENT PARTS | | | |
|-------------------|-------------|-------------------------------|--------------|
| ITEM | PART NUMBER | DESCRIPTION | QTY PER TOOL |
| 9 | 310582-1 | HANDLE, Ratchet | 1 |
| 10 | 354256-1 | HANDLE, Plastic | 1 |
| 11 | 310579-1 | PAWL, Ratchet | 2 |
| 12 | 17934-1 | PIN, Shear-Proof, Grooved | 1 |
| 13 | 313033-2 | PIN | 1 |
| 14 | 310578-1 | LINK, Toggle | 2 |
| 15 | 1320532-1 | PIN, Toggle Link | 2 |
| 16 | 310690-1 | SPRING, Extension | 1 |
| 17 | 852980-1 | LABEL, Vinyl, Five-Color | 1 |
| 18 | 18202-1 | E-RING, Bowed | 1 |
| 19 | 1-21113-6 | E-RING, External | 1 |
| 20 | 1213160-1 | PIN | 1 |
| 21 | 3-21028-8 | PIN, Slotted, .094 D × .630 L | 1 |
| 22 | 904139-1 | CRIMPING DIE, Indenter | 1 |
| 23 | 662903-2 | CRIMPING DIE, Anvil | 1 |
| 24 | 2-21002-4 | SCREW, Button, 8-32 × .75 L | 2 |

Figure 6 (end)

7. REVISION SUMMARY

Revisions to this instruction sheet per EC 0990-1712-03 include:

- Update document to corporate requirements
- Changed gage dimensions in Figure 5