

37mm (1.4 ") 5x8 SINGLE COLOR DOT MATRIX DISPLAY



SUN LED

Email : sales@us.sunled.com

Web Site : www.sunled.com

XMUG41C

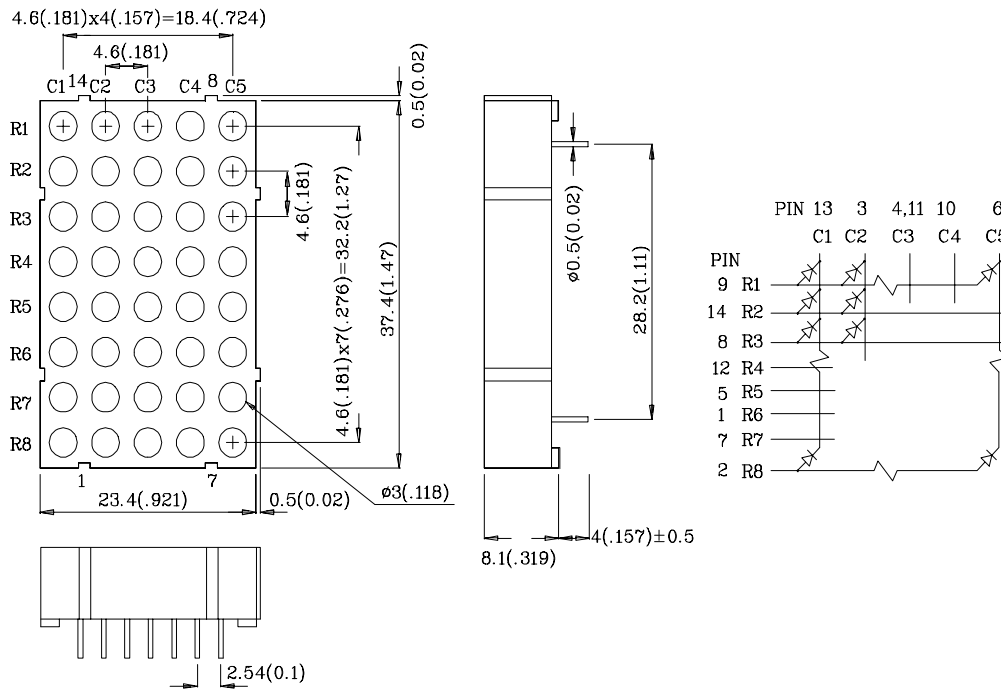

Notes:

1. All dimensions are in millimeters (inches).
2. Tolerance is $\pm 0.25(0.01)$ unless otherwise noted.

| Absolute maximum ratings (T _A =25°C) | | UG (GaP) | Unit |
|---|---------------------|-------------|------|
| Reverse voltage | V _R | 5 | V |
| Forward current | I _F | 25 | mA |
| Forward current (peak) 1/10Duty cycle 0.1ms pulse width | i _{FS} | 140 | mA |
| Power dissipation | P _T | 105 | mW |
| Operating temperature | T _A | -40 ~ +85 | °C |
| Storage temperature | T _{stg} | | |
| Lead solder temperature [2mm below package base] | 260°C For 5 Seconds | | |

| Operating Characteristics (T _A =25°C) | | UG (GaP) | Unit |
|--|-------------------|-------------|------|
| Forward voltage (typ.) (I _F =10mA) | V _F | 2.0 | V |
| Forward voltage (max.) (I _F =10mA) | V _F | 2.5 | V |
| Reverse current (V _R =5V) | I _R | 10 | uA |
| Wavelength at peak emission (I _F =10mA) | λ _{peak} | 565 | nm |
| Wavelength at Dominate emission (I _F =10mA) | λ _D | 568 | nm |
| Spectral Line half-width (I _F =10mA) | Δλ | 30 | nm |
| Capacitance (V _F =0V, f=1MHz) | C | 15 | pF |

| Part Number | Emitting Color | Emitting Material | Luminous Intensity (I _F =10mA) ucd | | Wavelength nm λ _P | Description |
|----------------|-------------------|----------------------|--|-------|------------------------------------|----------------|
| | | | min. | typ. | | |
| XMUG41C | Green | GaP | 4700 | 11990 | 565 | Column Cathode |

XMUG41C

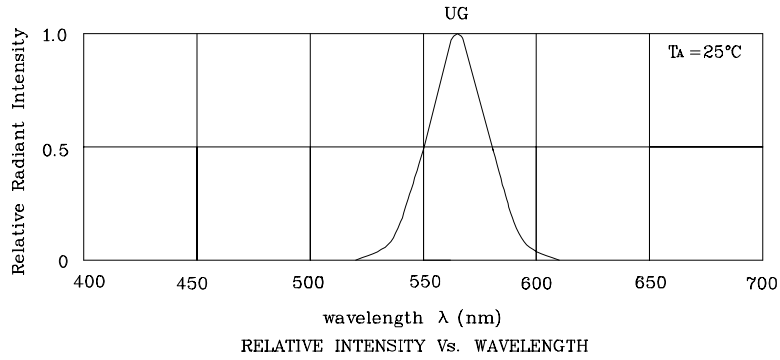

❖UG

