

**7.62mm (0.3") DUAL DIGIT
NUMERIC DISPLAY**



SUN LED

Email : sales@us.sunled.com

Web Site : www.sunled.com

XDUR07A2

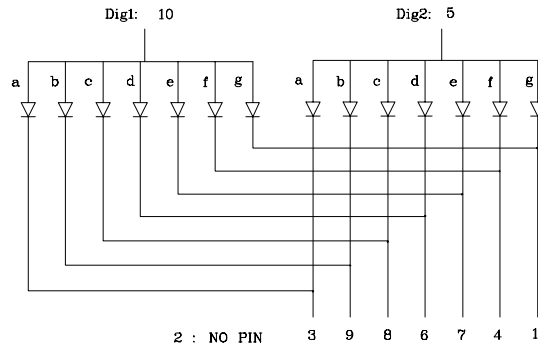
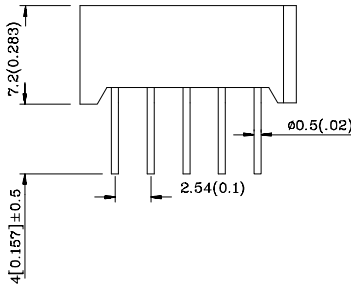
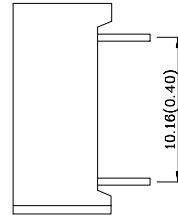
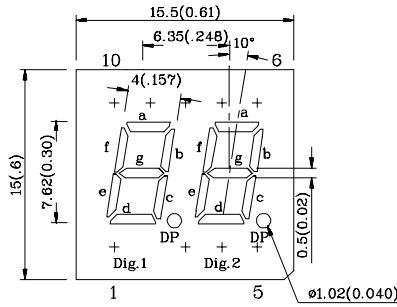

Notes:

1. All dimensions are in millimeters (inches).
2. Tolerance is $\pm 0.25(0.01)$ unless otherwise noted.

Absolute maximum ratings (T _A =25°C)		UR (GaAsP/GaP)	Unit
Reverse voltage	V _R	5	V
Forward current	I _F	30	mA
Forward current (peak) 1/10Duty cycle 0.1ms pulse width	i _F S	160	mA
Power dissipation	P _T	105	mW
Operating temperature	T _A	-40 ~ +85	°C
Storage temperature	T _{stg}		
Lead solder temperature [2mm below package base]		260°C For 5 Seconds	

Operating Characteristics (T _A =25°C)		UR (GaAsP/GaP)	Unit
Forward voltage (typ.) (I _F =10mA)	V _F	1.9	V
Forward voltage (max.) (I _F =10mA)	V _F	2.5	V
Reverse current (V _R =5V)	I _R	10	uA
Wavelength at peak emission (I _F =10mA)	λ _{peak}	627	nm
Wavelength at Dominate emission (I _F =10mA)	λ _D	625	nm
Spectral Line half-width (I _F =10mA)	Δλ	45	nm
Capacitance (V _F =0V, f=1MHz)	C	15	pF

Part Number	Emitting Color	Emitting Material	Luminous Intensity (I _F =10mA) ucd		Wavelength nm λ _P	Description
			min.	typ.		
XDUR07A2	Red	GaAsP/GaP	800	1890	627	Common Anode

XDUR07A2

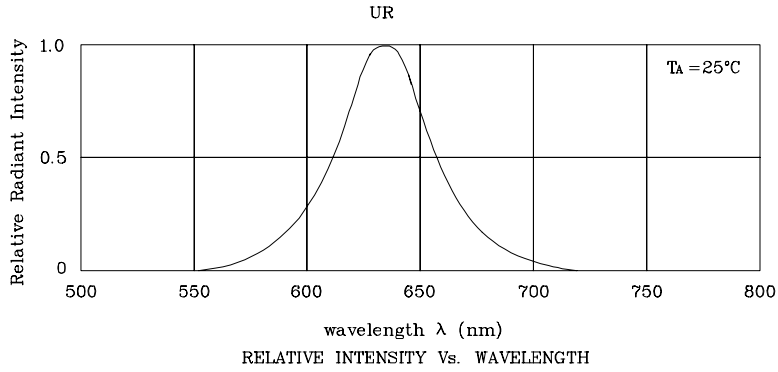

◆UR

