

GENERAL PURPOSE SILICON DETECTOR/PREAMPLIFIER

These detector/preamp hybrids combine planar diffused photodiode chips with monolithic op-amps in the transimpedance amplifier configuration. The feedback capacitor and resistor are connected externally by the user, allowing customization of the feedback circuit. The op-amps utilize JFET inputs for low input offset currents, and exhibit gain bandwidth products of 28MHz. The user can also choose between red, blue or UV enhanced spectral response, and between active photodetector areas of 100mm² and 5.1mm². As an option, volume users can specify internally mounted resistors and capacitors.

AMPLIFIER SPECIFICATIONS

Input Offset Voltage (max.):	3.0mV	Supply Voltage:	±5V to ±15V
Input Offset Current (typ.):	3.0pA	Power Dissipation:	360mW
Input Bias Current (typ.):	15.0pA	Operating Temperature:	-20°C to 85°C
Input Noise Current (typ. at 100Hz):	0.01pA/√Hz	Storage Temperature:	-25°C to 100°C
Input Noise Voltage (typ.) at 100Hz:	20nV/√Hz	Lead Temperature:	300°C
at 1kHz:	15nV/√Hz	(Soldering, 10 sec.)	
Slew Rate:	60V/μs	Differential Op-Amp Input Voltage:	±30V
Typ. Gain Bandwidth Product:	28MHz	Output Short Circuit Duration:	continuous

DETECTOR SPECIFICATIONS

Part Number	Total Area (mm ²)	Active Area (dia.) (in)	Spectral Enhancement	Typical Responsivity (A/W)	Shunt Resistance at 0V Min. (MΩ)	Capacitance		Dark Current at 10V Max. (nA)
						at 0V (pF)	at 10V (pF)	
SD 100-41-21-231	5.1	0.100	Red/IR	0.55 @ 940nm	300	87	18	10
SD 100-42-22-231	5.1	0.100	Blue/Visible	0.28 @ 450nm	300	87	18	10
SD 100-43-23-232	5.1	0.100	UV	0.15 @ 365nm	300	87	18	10
SD 444-41-21-261	100	0.444	Red/IR	0.55 @ 940nm	15	1700	340	150
SD 444-42-22-261	100	0.444	Blue/Visible	0.28 @ 450nm	15	1700	340	150
SD 444-43-23-262	100	0.444	UV	0.15 @ 365nm	15	1700	340	150

* All values at 23°C

Absolute Spectral Responsivity

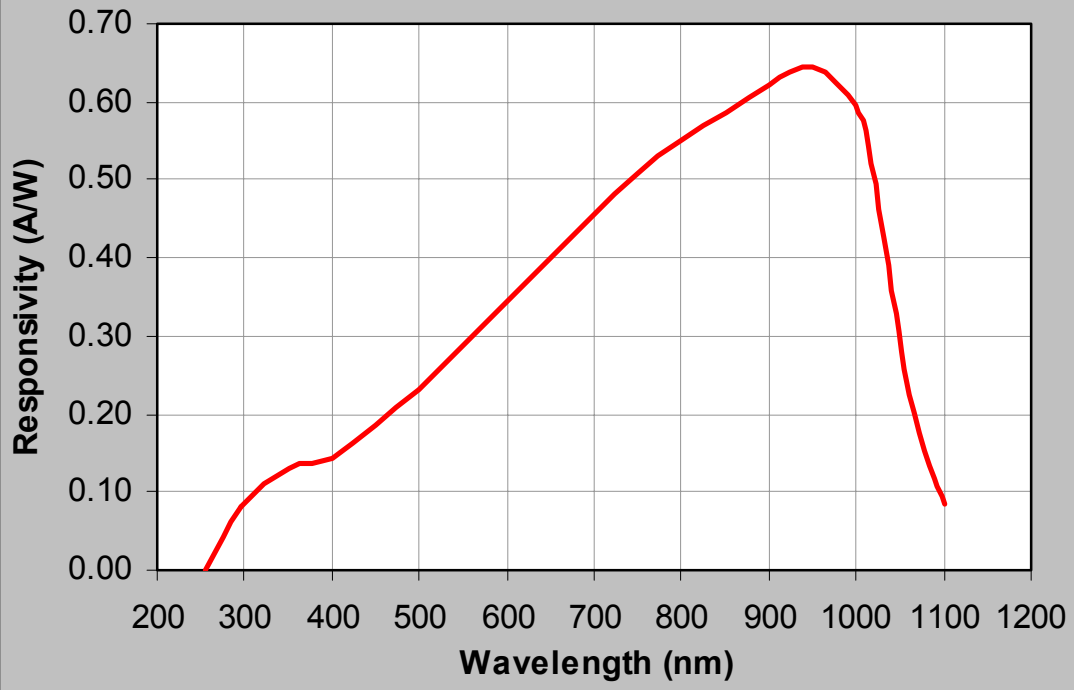

SCHEMATIC AND WIRING DIAGRAM

PHOTOVOLTAIC MODE

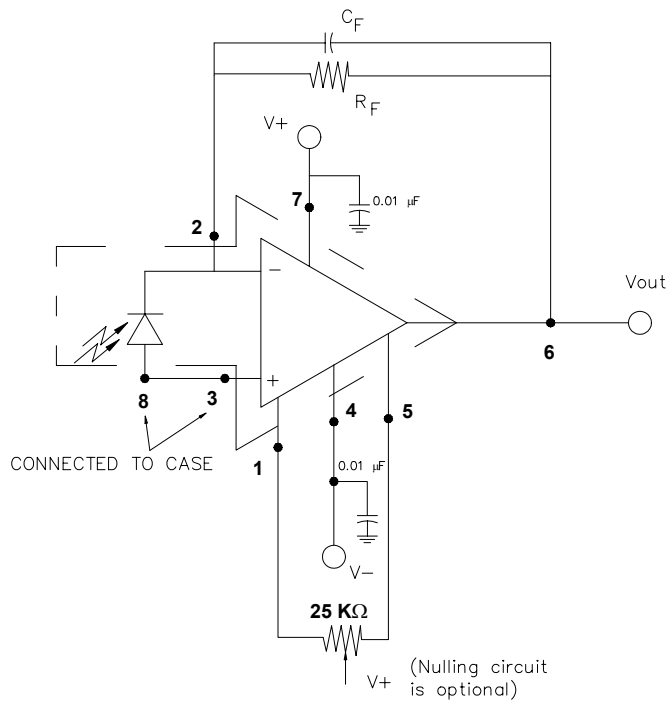

Note: Components shown outside the dashed area are external to the device, and must be supplied by the user.

PHOTOCONDUCTIVE MODE

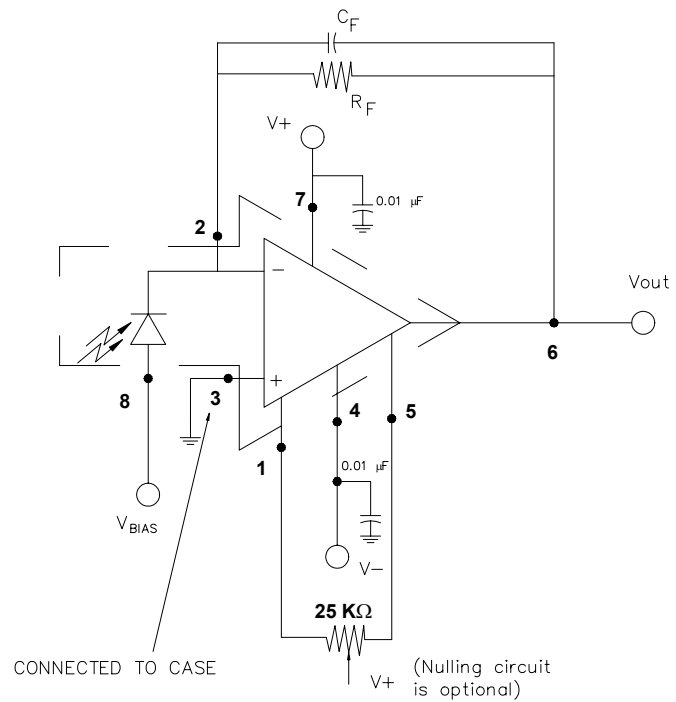

Note: Components shown outside the dashed area are external to the device, and must be supplied by the user.

Dimensional Outlines

SD 100-41-21-231

SD 100-42-22-231

SD 100-43-23-232

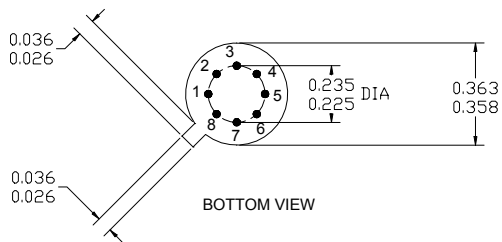
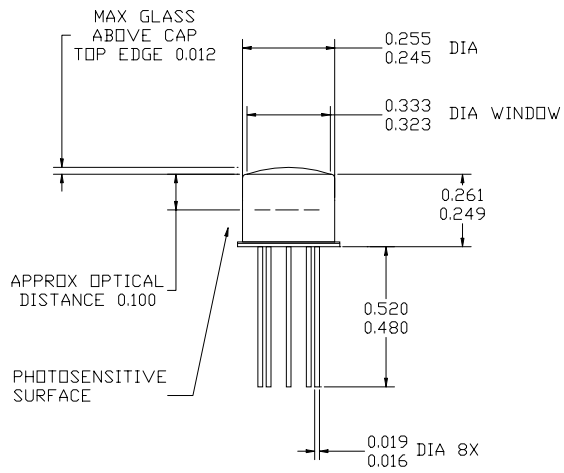

SD 444-41-21-261

SD 444-42-22-261

SD 444-43-23-262

