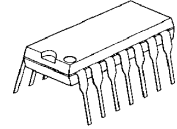
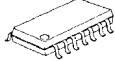

### 3D SURROUND AUDIO PROCESSOR

**■ GENERAL DESCRIPTION**

The **NJM2701** is a 3D surround audio processor regenerating the 3D surround sound with only two speakers. The **NJM2701** is suitable for audio applications, which are speaker system for mini components, CD radio cassette, multimedia speaker systems, TV and others.

**■ PACKAGE OUTLINE**

**NJM2701D**

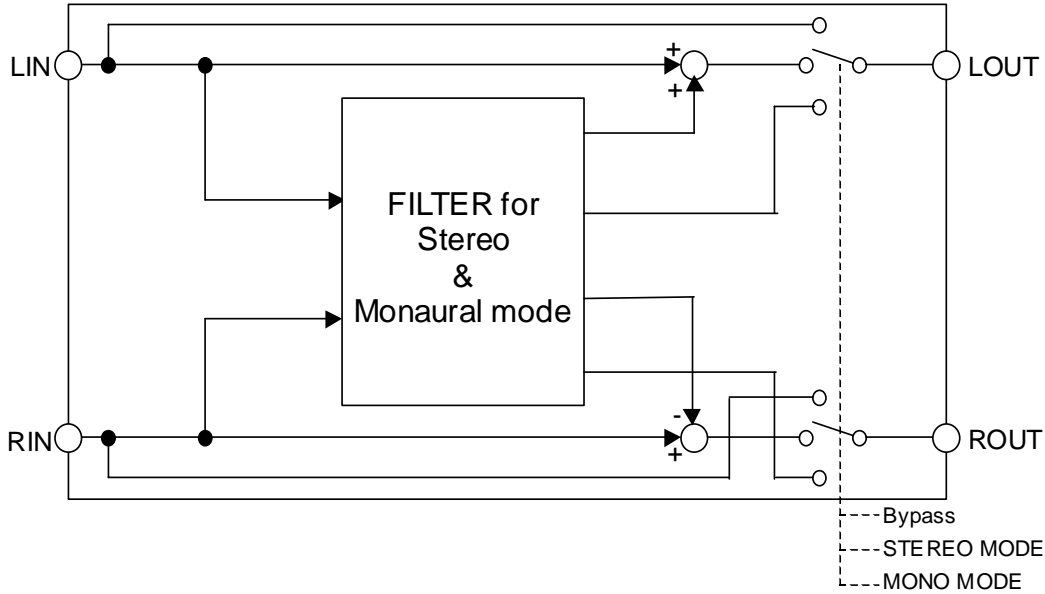
**NJM2701M**
**■ FEATURES**

- Operating Voltage                             4.7 to 13V
- Stereo mode
  - Stable center image and Natural sound field
  - High quality Surround
  - Free speaker interval
- Monaural mode (Mono-to-Stereo Synthesis)
- Surround control (Stereo mode only)
- Internal Mode Control Switch
- Bipolar Technology
- Package Outline                                 DIP14, DMP14

**■ BLOCK DIAGRAM**

# NJM2701

## ■ ABSOLUTE MAXIMUM RATING (Ta=25°C)

PARAMETER	SYMBOL	RATINGS	UNIT
Supply Voltage	V <sup>+</sup>	14	V
Power Dissipation	P <sub>D</sub>	(DIP14) 500 (DMP14) 350	mW
Operating Temperature Range	T <sub>opr</sub>	-40 to +85	°C
Storage Temperature Range	T <sub>stg</sub>	-40 to +125	°C

## ■ OPERATING VOLTAGE

PARAMETER	SYMBOL	TEST CONDITION	MIN.	TYP.	MAX.	UNIT
Operating Voltage	V <sup>+</sup>	-	4.7	12.0	13.0	V

## ■ ELECTRICAL CHARACTERISTICS (V<sup>+</sup>=12V, Ta=25°C unless otherwise specified)

PARAMETER	SYMBOL	TEST CONDITION					MIN.	TYP.	MAX.	UNIT	
		INPUT		OUTPUT	MODE	VR					
		L	R								
Operating Current	I <sub>cc</sub>	No Signal	0	0	-	BYPASS	-	2.9	5.7	8.6	mA
			0	0	-	Stereo	MAX	2.9	5.8	8.7	
			0	0	-	Mono	-	3.0	5.9	8.9	

## ● AC CHARACTERISTICS

(V<sup>+</sup>=12V, Ta=25°C, V<sub>IN</sub>=-10dBV(316mVrms), f=1kHz, RL=4.7kΩ, unless otherwise specified)

PARAMETER	SYMBOL	TEST CONDITION					MIN.	TYP.	MAX.	UNIT	
		INPUT		OUTPUT	MODE	VR					
		L	R								
Maximum Input Voltage	V <sub>IM</sub>	f=1kHz T.H.D.=3%	V <sub>IN</sub> 0	0 V <sub>IN</sub>	L R	BYPASS	-	9.9 (3.1)	11.9 (3.9)	-	dBV (Vrms)
		f=100Hz T.H.D.=3%	V <sub>IN</sub> 0	0 V <sub>IN</sub>	L R	Stereo	MAX	-3.8 (0.6)	-1.8 (0.8)	-	
		f=1kHz T.H.D.=3%	V <sub>IN</sub> V <sub>IN</sub>	0 0	L R	Mono	-	6.9 (2.2)	8.9 (2.8)	-	
Output Noise	V <sub>NO</sub>	R <sub>g</sub> =0Ω A-Weighted	0	0	L R	BYPASS	-	-	-112 (2.5)	-106 (5.0)	dBV (μVrms)
		R <sub>g</sub> =0Ω A-Weighted	0	0	L R	Stereo	MAX	-	-100 (10)	-94 (20)	
		R <sub>g</sub> =0Ω A-Weighted	0	0	L R	Mono	-	-	-103 (7.1)	-97 (14.1)	

## ● AC CHARACTERISTICS

( $V_+ = 12V, T_a = 25^\circ C, V_{IN} = -10dBV(316mV_{rms}), f = 1kHz, R_L = 4.7k\Omega$ , unless otherwise specified)

PARAMETER	SYMBOL	TEST CONDITION						MIN.	TYP.	MAX.	UNIT
		INPUT		OUTPUT	MODE	VR					
		L	R								
Total Harmonic Distortion	T.H.D	f=1kHz	$V_{IN}$ 0	0 $V_{IN}$	L R	BYPASS	-	-	0.005	0.01	%
		f=1kHz $V_{in} = -20dBV$	$V_{IN}$ 0	0 $V_{IN}$	L R	Stereo	MAX	-	0.1	0.5	
		f=1kHz	$V_{IN}$ $V_{IN}$	0 0	L R	Mono	-	-	0.1	0.5	
Bypass Gain	$G_{VBYP}$	f=1kHz	$V_{IN}$ 0	0 $V_{IN}$	L R	BYPASS	-	-1.0	0.0	1.0	dB
Surround Gain	$G_{VSUR}$	f=100Hz $V_{in} = -20dBV$	$V_{IN}$ 0	0 $V_{IN}$	L R	Stereo	MAX	10.7	12.7	14.7	dB
		f=100Hz $V_{in} = -20dBV$	0 $V_{IN}$	$V_{IN}$ 0	L R	Stereo	MAX	8.4	10.4	12.4	
		f=100Hz $V_{in} = -20dBV$	$V_{IN}$ 0	0 $V_{IN}$	L R	Stereo	MIN	3.6	5.6	7.6	
		f=1kHz	$V_{IN}$ $V_{IN}$	0 0	L R	Mono	-	1.0	3.0	5.0	

## ● CONTROL CHARACTERISTICS ( $V_+ = 12V, T_a = 25^\circ C$ unless otherwise specified)

PARAMETER	SYMBOL	TEST CONDITION						MIN.	TYP.	MAX.	UNIT
		INPUT		OUTPUT	MODE	VR					
		L	R								
Mode Select Control Voltage	$V_{MODE}$	$V_{IN} =$ High Level	-	-	-	-	-	2.0	-	$V_+$	V
		$V_{IN} =$ Low Level	-	-	-	-	-	0.0	-	0.7	

## ■ MODE SWITCH

MODE	SW1	SW2	NOTES
BYPASS	L	-	Input Through
Stereo	H	L	Surround Mode (Stereo Input)
Mono	H	H	Surround Mode (Mono Input)

# NJM2701

## ■ TERMINAL DESCRIPTION

PIN NO.	SYMBOL	FUNCTION	EQUIVALENT CIRCUIT	VOLTAGE
1	FIL1	Filter Input		V+/2
2	FIL2	Filter Input		V+/2
3	VOL	Surround VR		V+/2
4 10	TEST1 TEST2	Test pin		V+/2

PIN NO.	SYMBOL	FUNCTION	EQUIVALENT CIRCUIT	VOLTAGE
5	VREFIN	Reference Voltage Input		$V+/2$
6	V+	Power Supply		$V+$
7	GND	GND		0V
8 9	SW2 SW1	Mode Control Switch		0V

# NJM2701

PIN NO.	SYMBOL	FUNCTION	EQUIVALENT CIRCUIT	VOLTAGE
11 12	ROUT LOUT	Rch Output Lch Output		V+/2
13 14	RIN LIN	Rch Input Lch Input		V+/2

## APPLICATION CIRCUIT

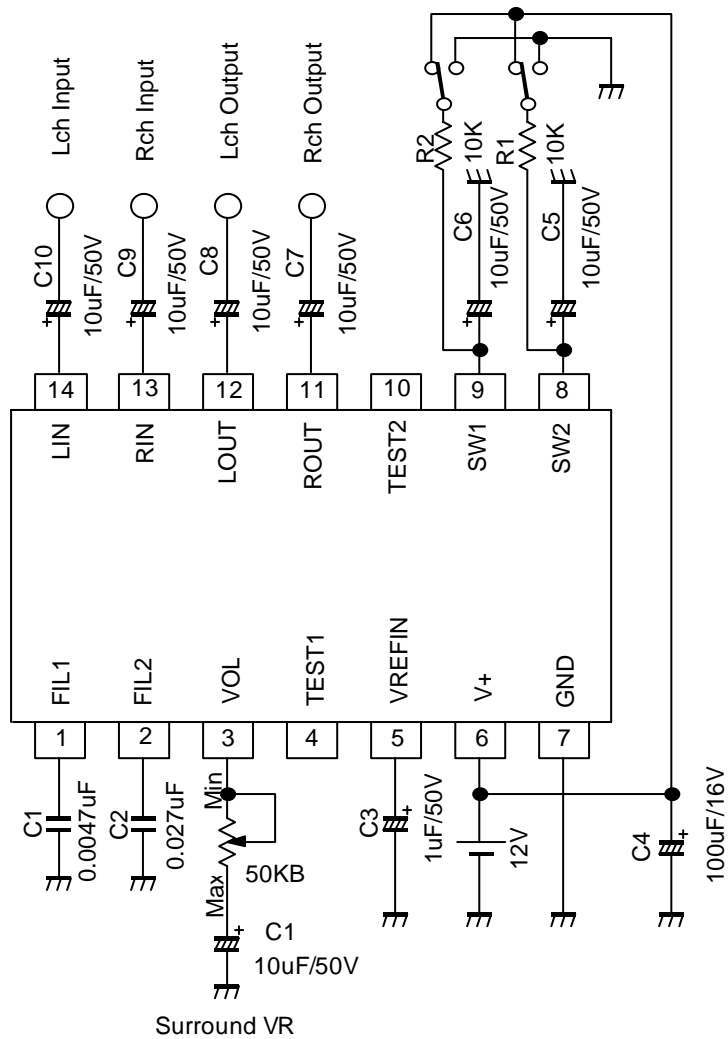

Note) In case of monaural mode (mono to stereo synthesis), input monaural signal into left channel input terminal (LIN).

Parts No.	Value	Tolerance	Parts No.	Value	Tolerance
R1,R2	10kΩ	5%	C3	1µF	20%
C1	0.0047µF	5%	C4	100µF	20%
C2	0.027µF	5%	C5,C6,C7,C8,C9,C10,C11	10µF	20%

# NJM2701

## TYPICAL CHARACTERISTICS

Supply Current vs Supply Voltage

V+=1 to 18V Ta=25degrees

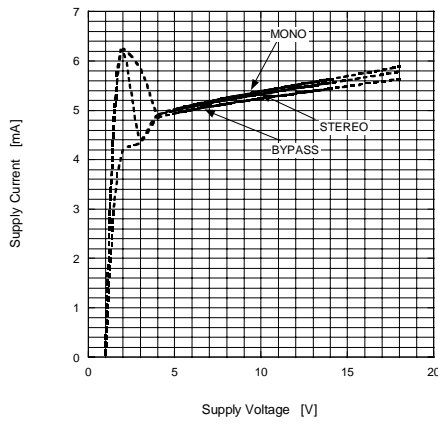

Supply Current vs Ambient Temperature

V+=12V

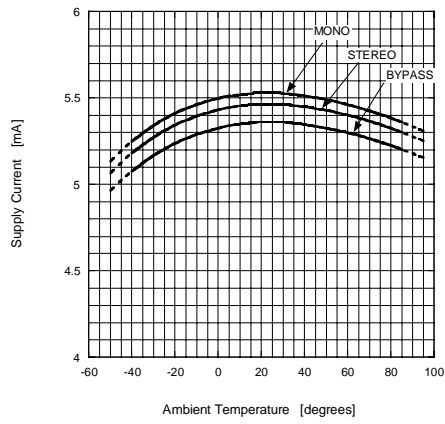

Maximum Input Voltage vs Supply Voltage (BYPASS)

Vin=Lch Vout=Lch f=1KHz RL=47Kohm Rg=25ohm Ta=25degrees

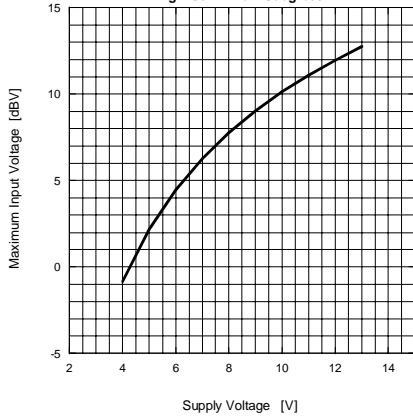

Maximum Input Voltage vs Supply Voltage (STEREO)

Vin=Lch Vout=Lch f=1KHz RL=47Kohm Rg=25ohm Ta=25degrees

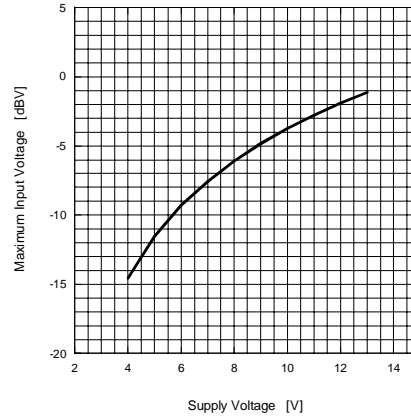

Maximum Input Voltage vs Supply Voltage (MONO)

Vin=Lch Vout=Lch f=1KHz RL=47Kohm Rg=25ohm Ta=25degrees

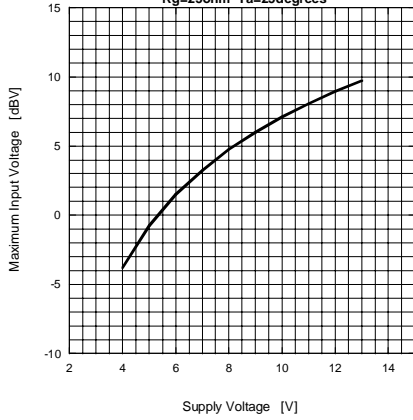



## TYPICAL CHARACTERISTICS

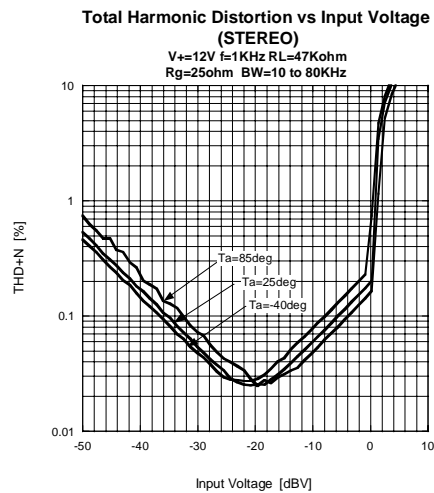
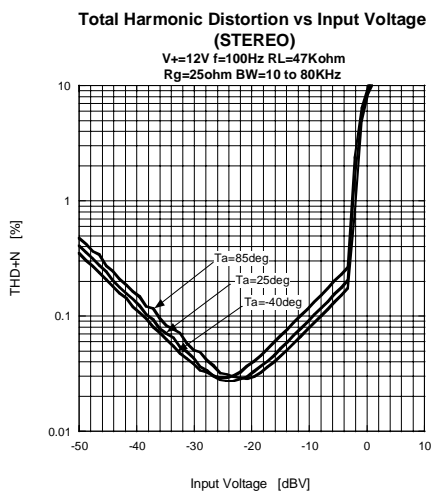
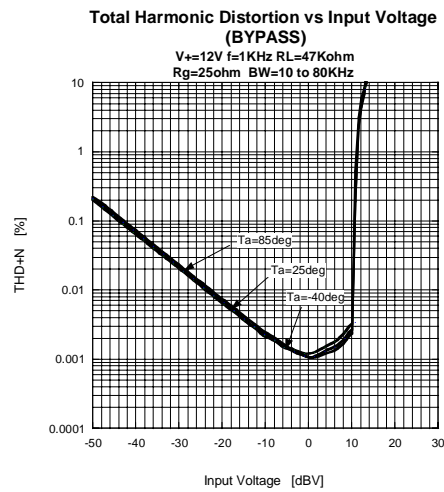
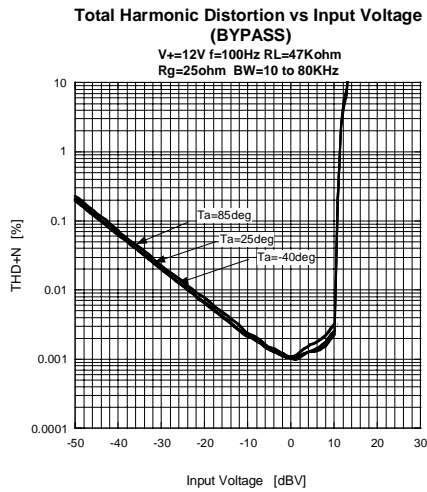
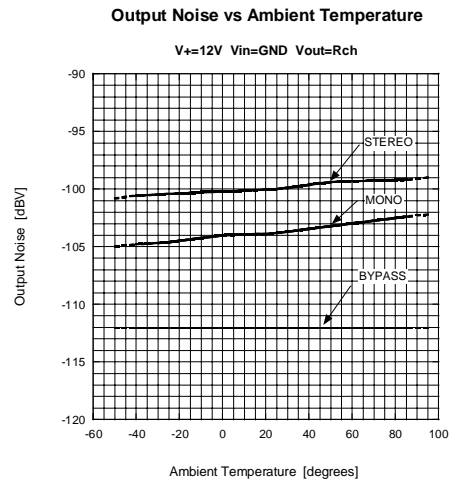
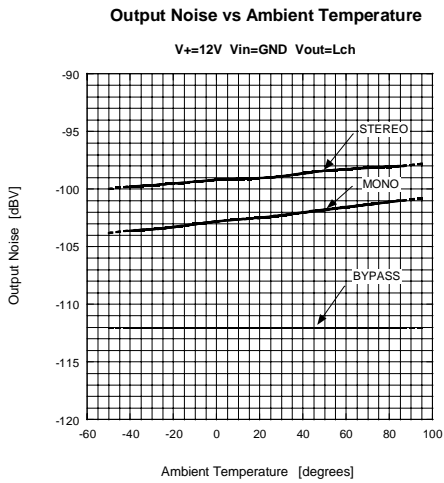

# NJM2701

## TYPICAL CHARACTERISTICS

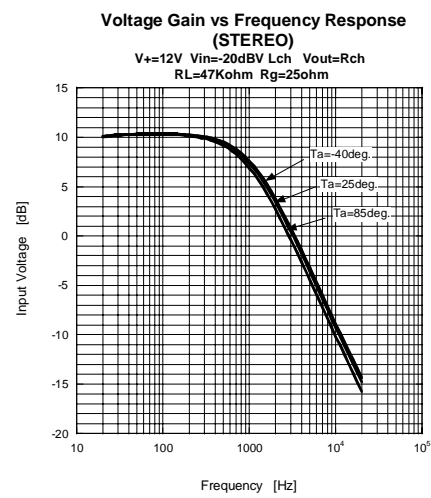
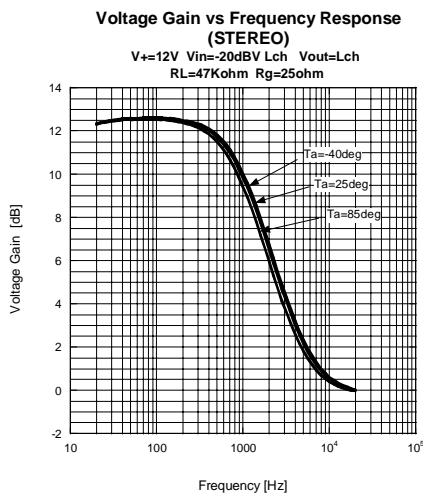
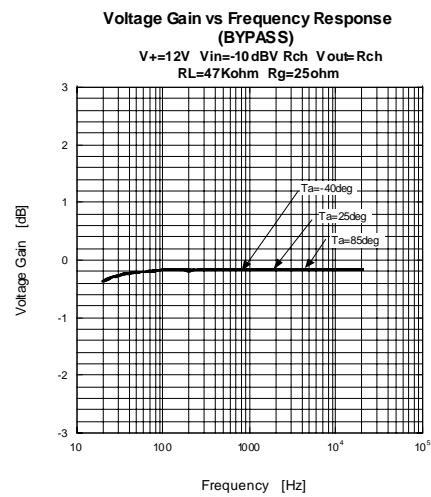
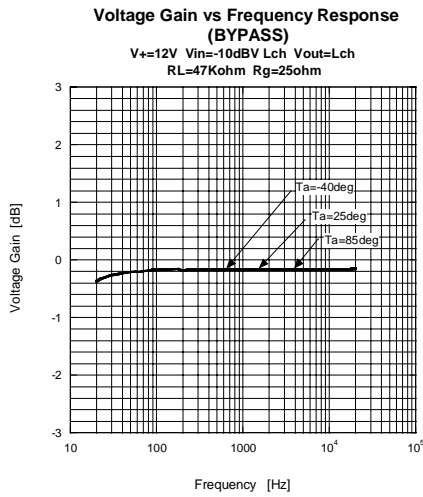
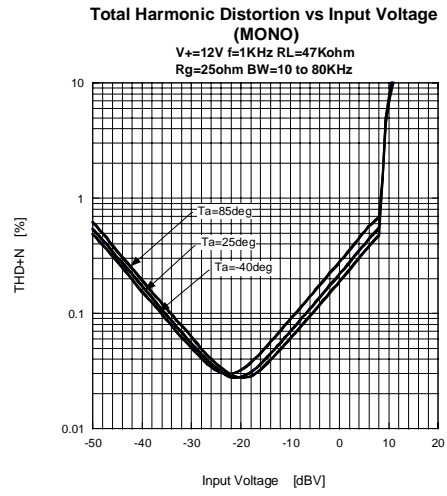
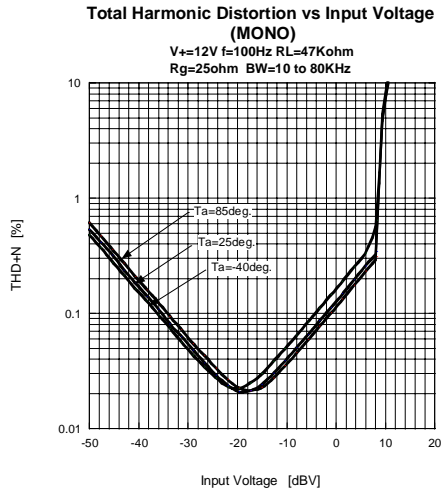

## TYPICAL CHARACTERISTICS

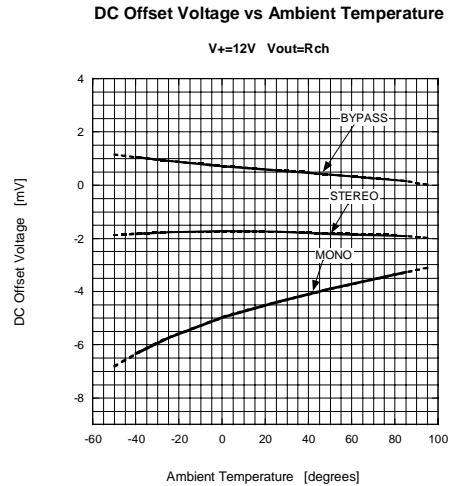
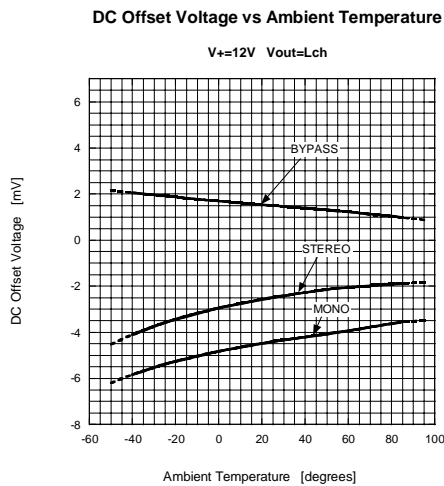
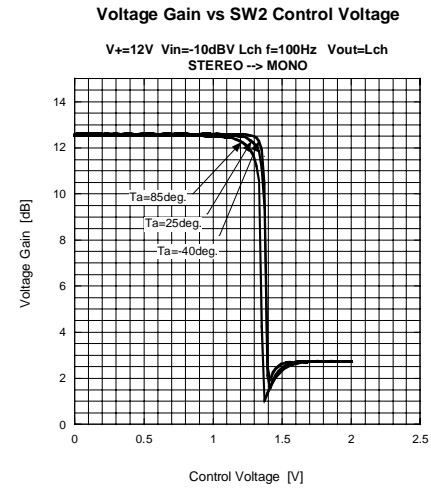
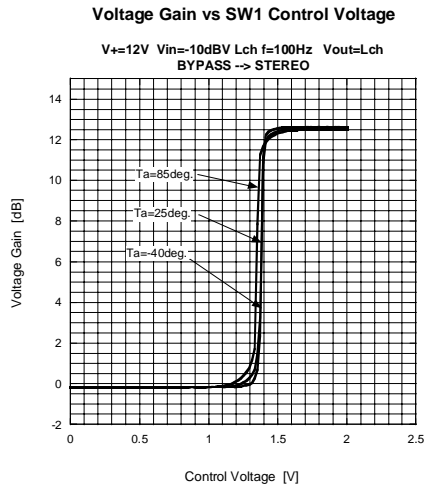
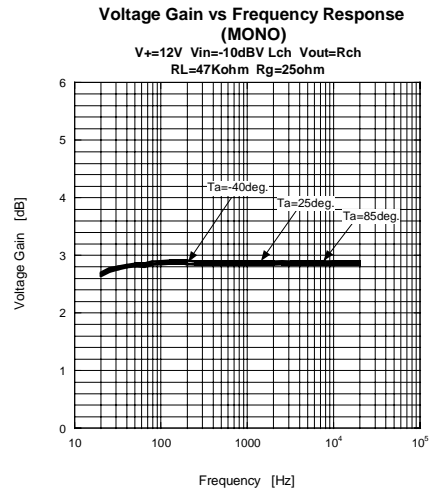
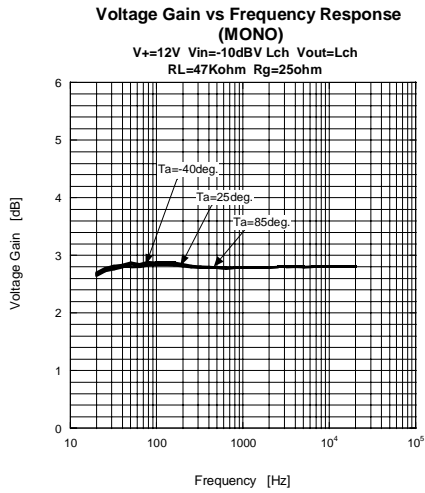

**[CAUTION]**  
 The specifications on this databook are only given for information, without any guarantee as regards either mistakes or omissions. The application circuits in this databook are described only to show representative usages of the product and not intended for the guarantee or permission of any right including the industrial rights.