

Video Amplifier Monolithic IC MM1186

Outline

This is a 75Ω, 2 system drive IC that supports S. Y input and V input have clamps, while C input does not have a clamp.

Features

1. Supports S
Three 75Ω 2 system drive circuits built in
2. Current consumption 24mA typ.
3. Power supply voltage SOP : 5V, SIP : 5~12V
4. Frequency response 7MHz
5. Crosstalk 60dB (at 4.43MHz)

Package

SOP-8C (MM1186XF)
SIP-8A (MM1186XS)

Applications

1. Free-standing VCR

Block Diagram

SOP-8C

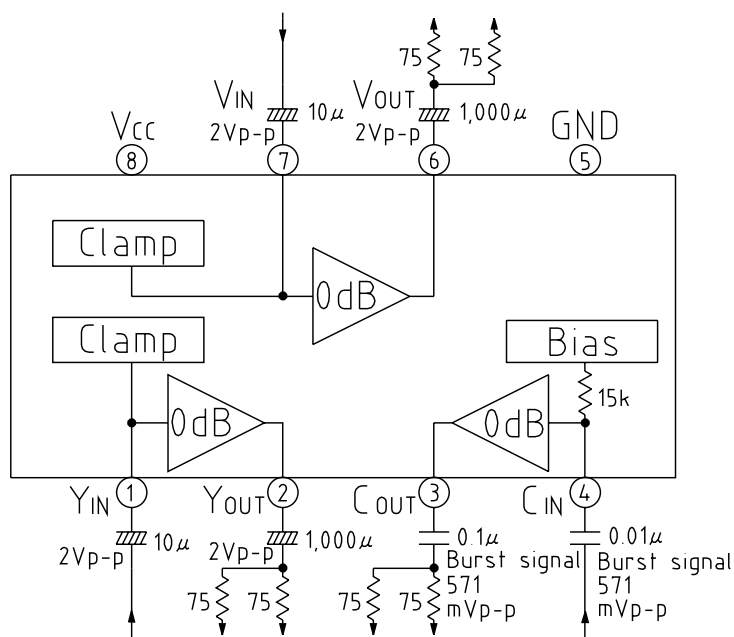

■ SIP-8A

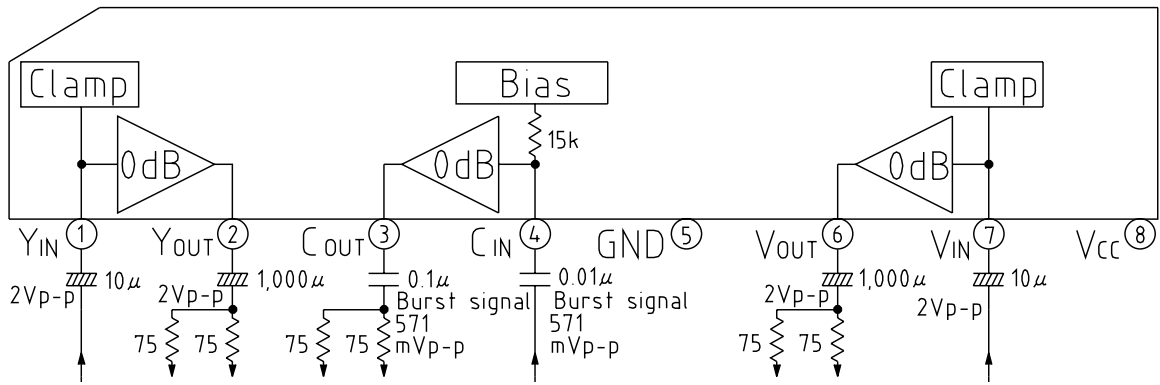

Pin Description

Pin no.	Pin name	Function	Internal equivalent circuit
1 7	Y _{IN} and V _{IN}	Y and V input	
2 6	Y _{OUT} and V _{OUT}	Y and V output	
3	C _{OUT}	C output	
4	C _{IN}	C input	
5	GND	GND	
8	V _{CC}	Power supply	

Absolute Maximum Ratings (Ta=25°C)

Item	Symbol	Ratings	Units
Storage temperature	T _{STG}	-40~+125	°C
Operating temperature	T _{OPR}	-20~+75	°C
Power supply voltage	V _{CC} max.	S : 15, F : 7	V
Allowable loss	P _d	S : 1000, F : 300	mW

Electrical Characteristics (Except where noted otherwise, Ta=25°C, V_{CC}=5.0V, SW1, SW2, SW3 : B, SG1, SG2, SG3 : no signal)

Item	Symbol	Measurement circuit	Measurement conditions	Min.	Typ.	Max.	Units
Operating power supply voltage	V _{CC}	V _{CC}		4.7	5.0	5.3	V
Consumption current	I _{CC}				24.0	33.0	mA
Y amp output SW1 : A							
Voltage gain	G _{V1}	TP1	SG1 : Sine wave, 2V _{P-P} , 0.1MHz	-0.5	0	0.5	dB
Frequency characteristic	F _{C1}		SG1 : Sweep signal, 2V _{P-P} 7MHz/0.1MHz	-1.0	0	1.0	dB
Differential gain	D _{G1}	TP2	SG1 : Staircase wave, 2V _{P-P} APL=10, 50, 90%		0	±3	%
Differential phase	D _{P1}		SG1 : Staircase wave, 2V _{P-P} APL=10, 50, 90%		0	±3	deg
Input dynamic range	D1	TP1	SG2 : Sine wave, 0.1MHz	2.6			V _{P-P}
Video amp output SW2 : A							
Voltage gain	G _{V2}	TP3	SG2 : Sine wave, 2V _{P-P} , 0.1MHz	-0.5	0	0.5	dB
Frequency characteristic	F _{C2}		SG2 : Sweep signal, 2V _{P-P} 7MHz/0.1MHz	-1.0	0	1.0	dB
Differential gain	D _{G1}	TP4	SG2 : Staircase wave, 2V _{P-P} APL=10, 50, 90%		0	±3	%
Differential phase	D _{P2}		SG2 : Staircase wave, 2V _{P-P} APL=10, 50, 90%		0	±3	deg
Input dynamic range	D2	TP3	SG2 : Sine wave, 0.1MHz	2.6			V _{P-P}
Chroma amp output SW3 : A							
Voltage gain	G _{V3}	TP5	SG3 : Sine wave, 2V _{P-P} , 0.1MHz	-0.5	0	0.5	dB
Frequency characteristic	F _{C3}		SG3 : Sweep signal, 2V _{P-P} 7MHz/0.1MHz	-1.0	0	1.0	dB
Crosstalk							
Y _{IN} → V _{OUT}	C _{T1}	TP3	SG1 : Sine wave, 2V _{P-P} , 4.43MHz V _{OUT} /Y _{IN} , SW1 : A		-60	-50	dB
Y _{IN} → C _{OUT}	C _{T2}	TP5	SG1 : Sine wave, 2V _{P-P} , 4.43MHz C _{OUT} /Y _{IN} , SW1 : A		-60	-50	dB
V _{IN} → Y _{OUT}	C _{T3}	TP1	SG2 : Sine wave, 2V _{P-P} , 4.43MHz Y _{OUT} /V _{IN} , SW2 : A		-60	-50	dB
V _{IN} → C _{OUT}	C _{T4}	TP5	SG2 : Sine wave, 2V _{P-P} , 4.43MHz C _{OUT} /V _{IN} , SW2 : A		-60	-50	dB
C _{IN} → Y _{OUT}	C _{T5}	TP1	SG3 : Sine wave, 2V _{P-P} , 4.43MHz Y _{OUT} /C _{IN} , SW3 : A		-60	-50	dB
C _{IN} → V _{OUT}	C _{T6}	TP3	SG3 : Sine wave, 2V _{P-P} , 4.43MHz V _{OUT} /C _{IN} , SW3 : A		-60	-50	dB

Measuring Circuit

■ SOP-8C

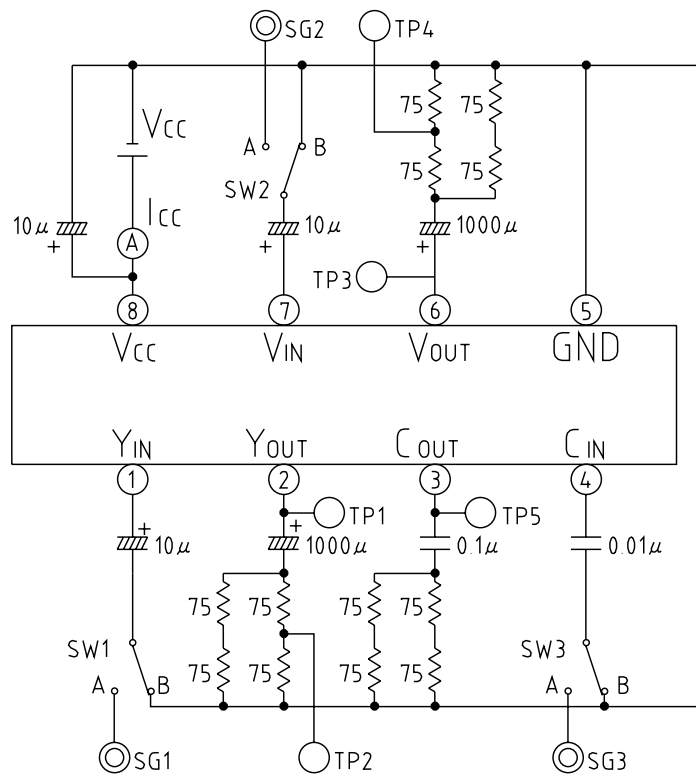

■ SIP-8A

