

MS3102

**RF & MICROWAVE TRANSISTORS
 SATCOM APPLICATIONS**

Features

- BALLASTED DIE GEOMETRY
- CLASS C OPERATION
- COMMON BASE CONFIGURATION

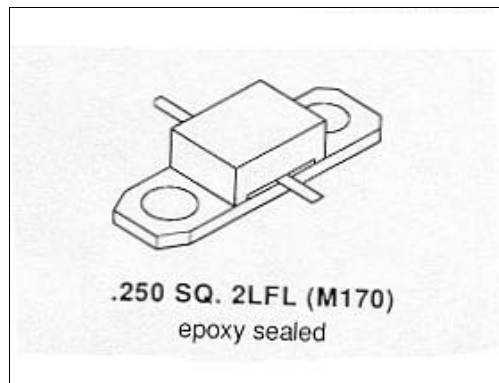

DESCRIPTION:

THE MS3102 IS A 28V CLASS C SILICON NPN TRANSISTOR DESIGNED FOR INMARSAT AND OTHER 1.65 GHz SATCOM APPLICATIONS. A GOLD METALLIZED EMITTER BALLASTED DIE GEOMETRY IS EMPLOYED PROVIDING HIGH GAIN AND EFFICIENCY. MS3102 IS PACKAGED IN A N EPOXY SEALED HOUSING.

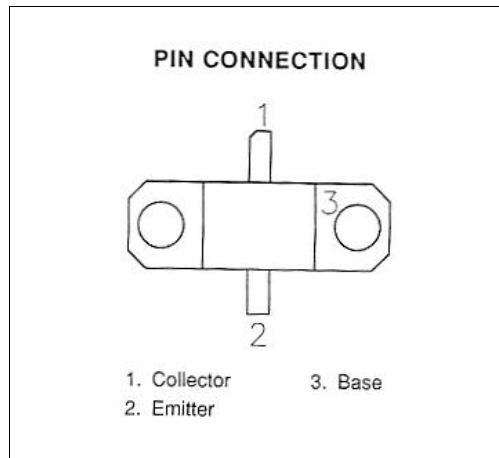

ABSOLUTE MAXIMUM RATINGS

Symbol	Parameter	Value	Unit
V_{CBO}	Collector-base Voltage	45	V
V_{EBO}	Emitter-base Voltage	3.5	V
I_C	Device Current	2.3	A
T_J	Junction Temperature	+200	°C
T_{STG}	Storage Temperature	-65 to +150	°C

Thermal Data

$R_{TH(J-C)}$	Thermal Resistance Junction-case	6.0	°C/W
---------------	----------------------------------	-----	------

ELECTRICAL SPECIFICATIONS (Tcase = 25°C)

STATIC

Symbol	Test Conditions		Value			Unit
			Min.	Typ.	Max.	
Bvcbo	I _C = 3 mA	I _E = 0 mA	45	---	---	V
Bvceo	I _C = 3 mA	I _B = 0 mA	12	---	---	V
Bvebo	I _E = 3 mA	I _C = 0 mA	3.5	---	---	V
HFE	V _{CE} =5V	I _C = 600 mA	15	---	150	---

DYNAMIC

Symbol	Test Conditions			Value			Unit
				Min.	Typ.	Max.	
P _{out}	f=1.65 GHz	P _{IN} = 0.8 W	V _{CE} =28V	10	---	---	W
η _c	f=1.65 GHz	P _{IN} = 0.8 W	V _{CE} =28V	11	---	---	dB
G _{pe}	f=1.65 GHz	P _{IN} = 0.8 W	V _{CE} =28V	48	---	---	%

PACKAGE MECHANICAL DATA

