

MODULATORS, BI-PHASE

0.2–18 GHz

SERIES MP

GENERAL INFORMATION

Bi-Phase modulators shift the phase of an RF signal by 180° upon application of a TTL logic signal. Logic 0 produces a reference (0°) phase and logic 1 changes the phase 180°. Bi-phase modulators can be used in carrier suppression systems. If an RF signal at a frequency f_c is applied to the RF terminal, and a square wave modulating signal, f_m , is applied to the bias terminal, many frequencies are generated at the RF output. They are f_c , $f_c \pm f_m$, $f_c \pm 2f_m$, ..., $f_c \pm nf_m$. The carrier, f_c , is suppressed a minimum of 20 dB on all models. Typical suppression on most models is 30 dB. The first order sidebands are each down approximately 4 dB, plus insertion loss. The even sidebands are down 25 dB, and the odd sidebands are as follows:

- 3rd order sidebands—10 dB
- 5th order sidebands—14 dB
- 7th order sidebands—18 dB, etc.

GENERAL SPECIFICATIONS

Frequency Range:	0.20 to 18.0 GHz
RF Impedance:	50 Ohms
D.C. Requirements:	For modulators with diodes, +5 Volts at +80 mA and -5Volts at -80 mA (Logic 0, reference Logic 1, 180°).
RF Power:	0.2 watts average, 10 watts peak.
Temperature Information:	Operating temperature from -55°C to +85°C.
Switching Speed:	Standard switching speed for all models is 500 nanosec. (750 nanosec. including storage and delay time). Any model can be switched in 35 nanoseconds (including storage and delay time) if required. However, the insertion loss will increase by 30%. If 10 nanoseconds is required add 1 to the model number when ordering.
Connectors:	SMA

ELECTRICAL PERFORMANCE

Model No.	Frequency Range GHz	Phase Accuracy		VSWR Maximum	Insertion Loss		Outline
		±Deg.	Maximum		Minimum/Maximum	dB	
MP-24	0.2-0.4	5.0	1.40	0.6/0.9	1		
MP-25	0.25-0.5	5.0	1.40	0.6/0.9	1		
MP-29	0.5-1.0	7.0	1.40	0.6/0.9	1		
MP-36	0.95-1.25	3.0	1.30	0.6/0.9	1		
MP-92	0.5-2.0	8.0	1.70	2.6/3.2	6		
MP-41	1.0-2.0	7.0	1.50	0.6/1.1	1		
MP-49	2.0-4.0	6.0	1.50	0.7/1.2	4		
MP-94	2.0-8.0	7.0	2.00	3.0/4.3	4		
MP-57	4.0-8.0	7.0	1.50	1.0/1.5	2		
MP-62	7.0-12.4	7.0	1.75	1.2/2.0	3		
MP-98	6.0-18.0	12.0	2.25	5.0/7.0	5		
MP-64	8.0-16.0	15.0	1.80	1.5/2.5	3		
MP-67	8.0-18.0	20.0	2.2	1.5/2.8	3		
MP-75	12.0-18.0	8.0	2.0	1.6/2.8	3		
MP-88	16.0-18.0	6.0	2.0	1.6/2.8	3		

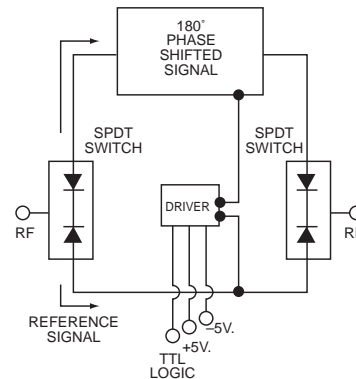
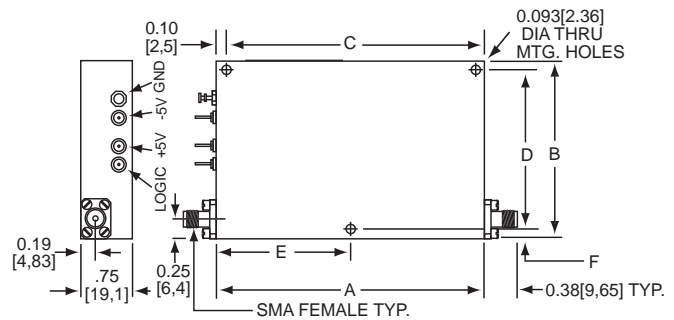
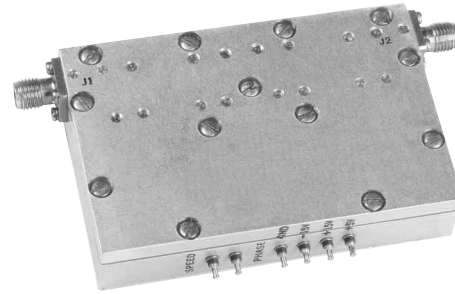

MECHANICAL OUTLINES

Outline	A in[mm]	B in[mm]	C in[mm]	D in[mm]	E in[mm]	F in[mm]
1	2.00[50,8]	1.25[31,75]	1.800[45,7]	1.000[25,4]	1.000[25,4]	0.12[3,05]
2	1.60[40,64]	1.25[31,75]	1.400[35,56]	1.000[25,4]	0.80[20,3]	0.12[3,05]
3	1.30[33,02]	1.38[35,1]	1.100[27,94]	1.130[28,70]	N/A 4 HOLES	0.12[3,05]
4	3.00[76,2]	1.25[31,75]	2.800[71,12]	1.000[25,4]	1.50[38,1]	0.12[3,05]
5	2.50[63,5]	1.00[25,4]	2.300[58,42]	0.800[20,3]	1.25[31,75]	0.10[2,5]
6	4.00[101,6]	2.00[50,8]	3.800[96,5]	1.800[45,7]	2.00[50,8]	0.10[2,5]

KEY: Inches[Millimeters] .XX ±.03 .XXX ±.010 [.X ±0.8 .XX ±0.25]