

# Thyristor Modules

## Thyristor/Diode Modules

$I_{TRMS} = 2 \times 100 \text{ A}$   
 $I_{TAVM} = 2 \times 64 \text{ A}$   
 $V_{RRM} = 800-1800 \text{ V}$

TO-240 AA

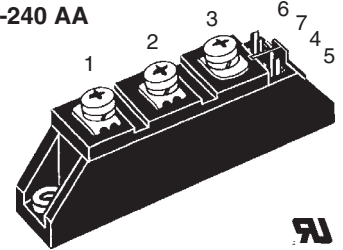

$V_{RSM}$	$V_{RRM}$	Type			Type		
$V_{DSM}$	$V_{DRM}$	Version			Version		
V	V	1 B	8 B	1 B	8 B	1 B	8 B
900	800	MCC 56-08	io1 B / io8 B	MCD 56-08	io1 B / io8 B		
1300	1200	MCC 56-12	io1 B / io8 B	MCD 56-12	io1 B / io8 B		
1500	1400	MCC 56-14	io1 B / io8 B	MCD 56-14	io1 B / io8 B		
1700	1600	MCC 56-16	io1 B / io8 B	MCD 56-16	io1 B / io8 B		
1900	1800	MCC 56-18	io1 B / io8 B	MCD 56-18	io1 B / io8 B		

Symbol	Conditions	Maximum Ratings	
$I_{TRMS}, I_{FRMS}$	$T_{VJ} = T_{VJM}$	100	A
$I_{TAVM}, I_{FAVM}$	$T_C = 83^\circ\text{C}; 180^\circ \text{ sine}$	64	A
	$T_C = 85^\circ\text{C}; 180^\circ \text{ sine}$	60	A
$I_{TSM}, I_{FSM}$	$T_{VJ} = 45^\circ\text{C};$ $V_R = 0$	t = 10 ms (50 Hz), sine t = 8.3 ms (60 Hz), sine	1500 A 1600 A
	$T_{VJ} = T_{VJM}$ $V_R = 0$	t = 10 ms (50 Hz), sine t = 8.3 ms (60 Hz), sine	1350 A 1450 A
$\int i^2 dt$	$T_{VJ} = 45^\circ\text{C}$ $V_R = 0$	t = 10 ms (50 Hz), sine t = 8.3 ms (60 Hz), sine	11 200 A <sup>2</sup> s 10 750 A <sup>2</sup> s
	$T_{VJ} = T_{VJM}$ $V_R = 0$	t = 10 ms (50 Hz), sine t = 8.3 ms (60 Hz), sine	9100 A <sup>2</sup> s 8830 A <sup>2</sup> s
$(di/dt)_{cr}$	$T_{VJ} = T_{VJM}$ f = 50 Hz, $t_p = 200 \mu\text{s}$ $V_D = \frac{2}{3} V_{DRM}$	repetitive, $I_T = 150 \text{ A}$	150 A/ $\mu\text{s}$
	$I_G = 0.45 \text{ A}$ $di_G/dt = 0.45 \text{ A}/\mu\text{s}$	non repetitive, $I_T = I_{TAVM}$	500 A/ $\mu\text{s}$
$(dv/dt)_{cr}$	$T_{VJ} = T_{VJM};$ $R_{GK} = \infty;$ method 1 (linear voltage rise)	$V_{DR} = \frac{2}{3} V_{DRM}$	1000 V/ $\mu\text{s}$
$P_{GM}$	$T_{VJ} = T_{VJM};$ $I_T = I_{TAVM};$	$t_p = 30 \mu\text{s}$ $t_p = 300 \mu\text{s}$	10 W 5 W
$P_{GAV}$			0.5 W
$V_{RGM}$			10 V
$T_{VJ}$			-40...+125 °C
$T_{VJM}$			125 °C
$T_{stg}$			-40...+125 °C
$V_{ISOL}$	50/60 Hz, RMS; $I_{ISOL} \leq 1 \text{ mA};$	t = 1 min t = 1 s	3000 V~ 3600 V~
$M_d$	Mounting torque (M5) Terminal connection torque (M5)		2.5-4.0/22-35 Nm/lb.in. 2.5-4.0/22-35 Nm/lb.in.
<b>Weight</b>	Typical including screws		90 g

Data according to IEC 60747 and refer to a single thyristor/diode unless otherwise stated. IXYS reserves the right to change limits, test conditions and dimensions

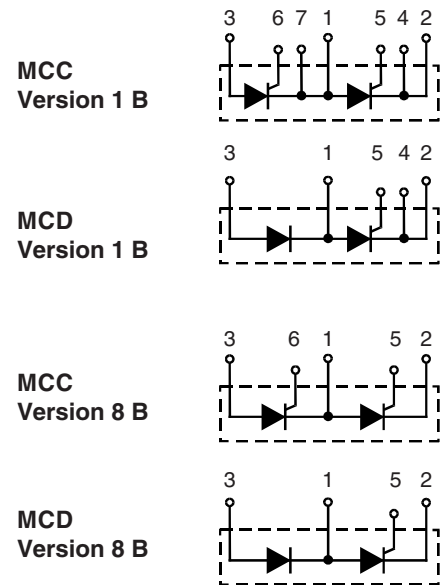

### Features

- International standard package, JEDEC TO-240 AA
- Direct copper bonded  $\text{Al}_2\text{O}_3$  -ceramic base plate
- Planar passivated chips
- Isolation voltage 3600 V~
- UL registered, E 72873
- Gate-cathode twin pins for version 1B

### Applications

- DC motor control
- Softstart AC motor controller
- Light, heat and temperature control

### Advantages

- Space and weight savings
- Simple mounting with two screws
- Improved temperature and power cycling
- Reduced protection circuits

Symbol	Conditions	Characteristic Values	
$I_{RRM}, I_{DRM}$	$T_{VJ} = T_{VJM}; V_R = V_{RRM}; V_D = V_{DRM}$	5	mA
$V_T, V_F$	$I_T/I_F = 200 \text{ A}; T_{VJ} = 25^\circ\text{C}$	1.57	V
$V_{T0}$	For power-loss calculations only ( $T_{VJ} = 125^\circ\text{C}$ )	0.85	V
$r_T$		3.7	m $\Omega$
$V_{GT}$	$V_D = 6 \text{ V}; T_{VJ} = 25^\circ\text{C}$	1.5	V
	$T_{VJ} = -40^\circ\text{C}$	1.6	V
$I_{GT}$	$V_D = 6 \text{ V}; T_{VJ} = 25^\circ\text{C}$	100	mA
	$T_{VJ} = -40^\circ\text{C}$	200	mA
$V_{GD}$	$T_{VJ} = T_{VJM}; V_D = 2/3 V_{DRM}$	0.2	V
$I_{GD}$		10	mA
$I_L$	$T_{VJ} = 25^\circ\text{C}; t_p = 10 \mu\text{s}; V_D = 6 \text{ V}$ $I_G = 0.45 \text{ A}; di_G/dt = 0.45 \text{ A}/\mu\text{s}$	450	mA
$I_H$	$T_{VJ} = 25^\circ\text{C}; V_D = 6 \text{ V}; R_{GK} = \infty$	200	mA
$t_{gd}$	$T_{VJ} = 25^\circ\text{C}; V_D = 1/2 V_{DRM}$ $I_G = 0.45 \text{ A}; di_G/dt = 0.45 \text{ A}/\mu\text{s}$	2	$\mu\text{s}$
$t_q$	$T_{VJ} = T_{VJM}; I_T = 150 \text{ A}; t_p = 200 \mu\text{s}; -di/dt = 10 \text{ A}/\mu\text{s}$ $V_R = 100 \text{ V}; dv/dt = 20 \text{ V}/\mu\text{s}; V_D = 2/3 V_{DRM}$	typ. 150	$\mu\text{s}$
$Q_S$	$T_{VJ} = T_{VJM}; I_T, I_F = 50 \text{ A}, -di/dt = 3 \text{ A}/\mu\text{s}$	100	$\mu\text{C}$
$I_{RM}$		24	A
$R_{thJC}$	per thyristor/diode; DC current per module	0.45	K/W
$R_{thJK}$	per thyristor/diode; DC current per module	0.225	K/W
	other values see Fig. 8/9	0.65	K/W
		0.325	K/W
$d_s$	Creepage distance on surface	12.7	mm
$d_A$	Strike distance through air	9.6	mm
$a$	Maximum allowable acceleration	50	m/s <sup>2</sup>

Optional accessories for module-type MCC 56 version 1 B  
 Keyed gate/cathode twin plugs with wire length = 350 mm, gate = yellow, cathode = red  
 Type **ZY 200L** (L = Left for pin pair 4/5) } UL 758, style 1385,  
 Type **ZY 200R** (R = right for pin pair 6/7) } CSA class 5851, guide 460-1-1

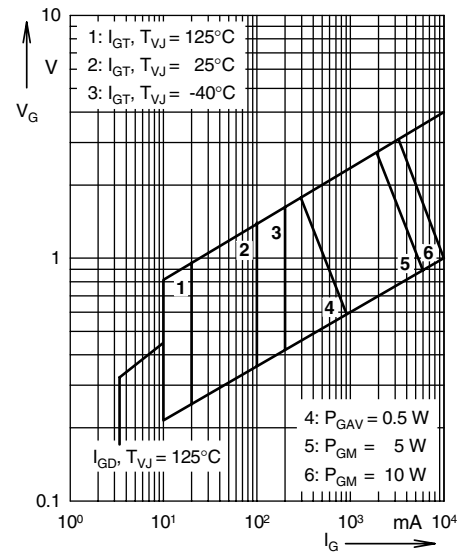

Fig. 1 Gate trigger characteristics

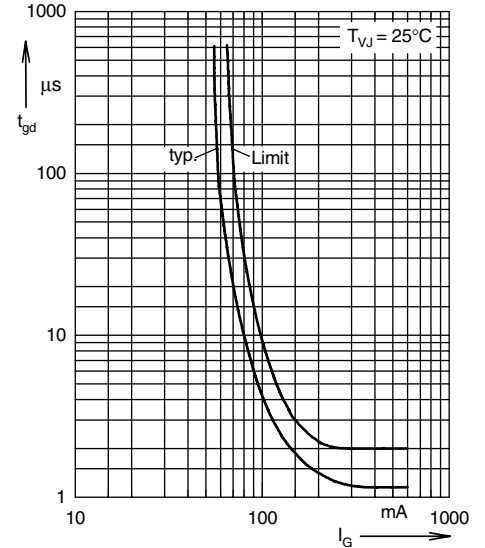
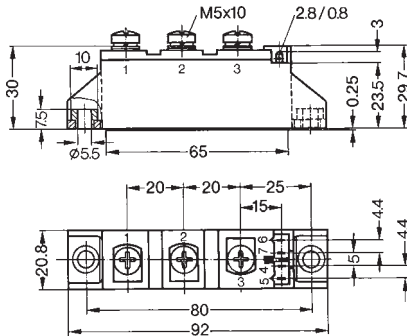

Fig. 2 Gate trigger delay time

**Dimensions in mm (1 mm = 0.0394")**

**MCC / MCD / MDC Version 1 B**



**MCC Version 8 B**

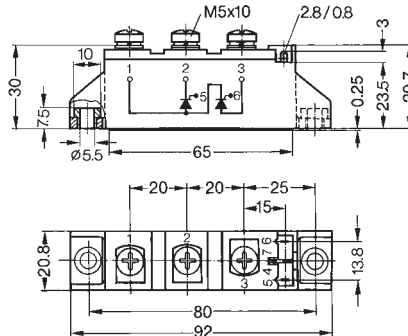

**MCD Version 8 B**

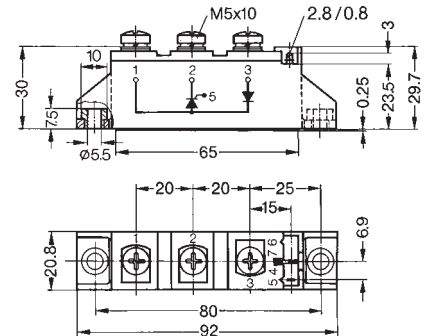

Version 1 or 8 without B in type designation = without insert in mount holes

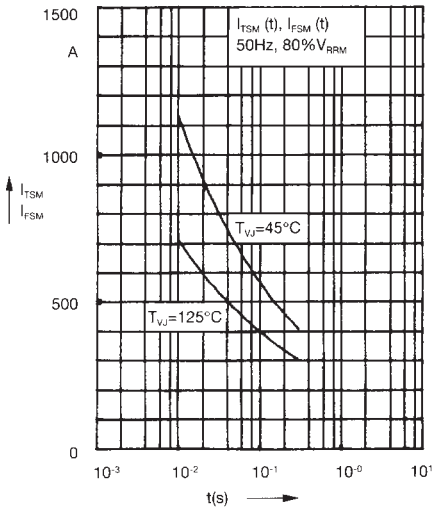

Fig. 3 Surge overload current  
 $I_{TSM}$ ,  $I_{FSM}$ : Crest value,  $t$ : duration

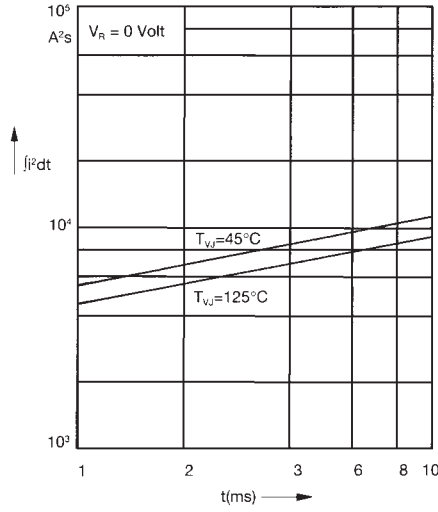

Fig. 4  $\int i^2 dt$  versus time (1-10 ms)

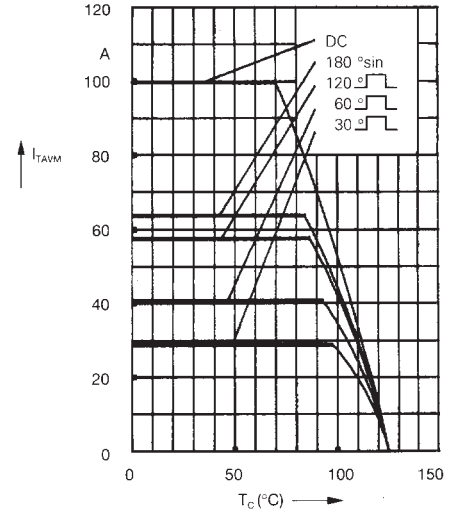

Fig. 4a Maximum forward current at case temperature

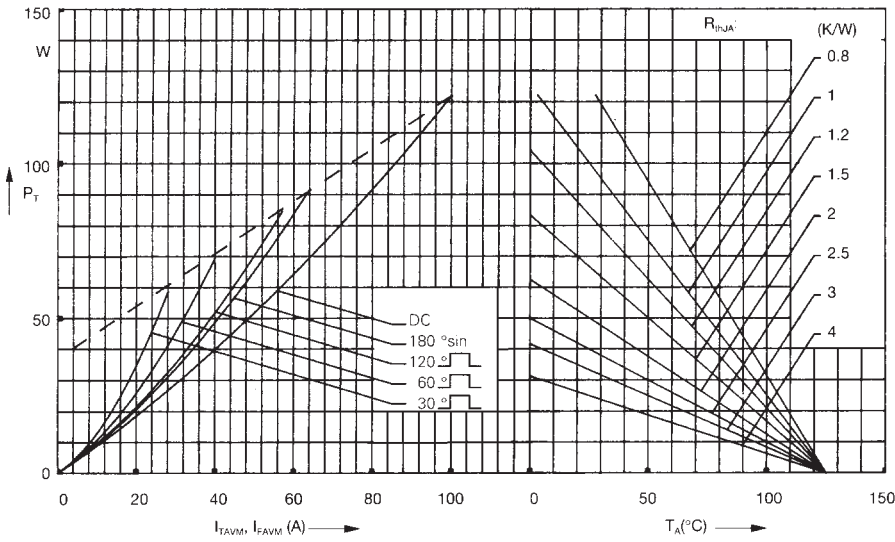

Fig. 5 Power dissipation versus on-state current and ambient temperature (per thyristor or diode)

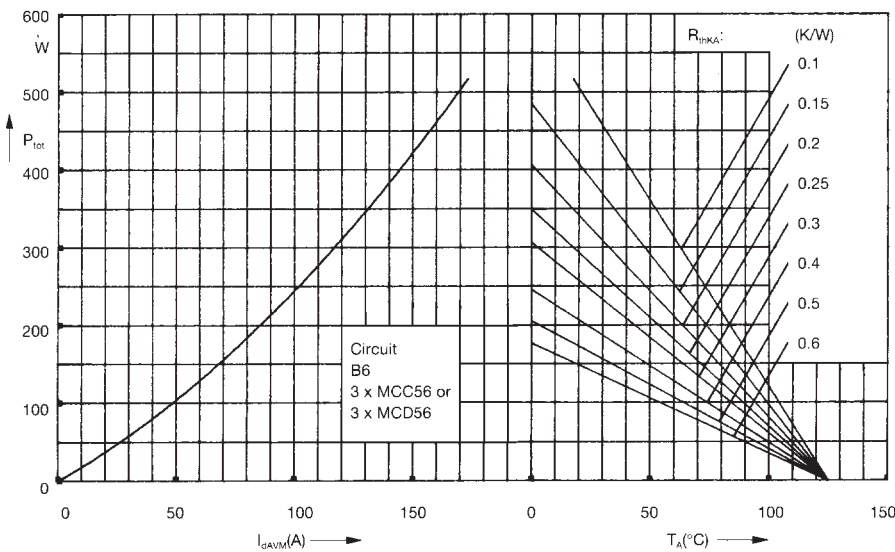

Fig. 6 Three phase rectifier bridge: Power dissipation versus direct output current and ambient temperature

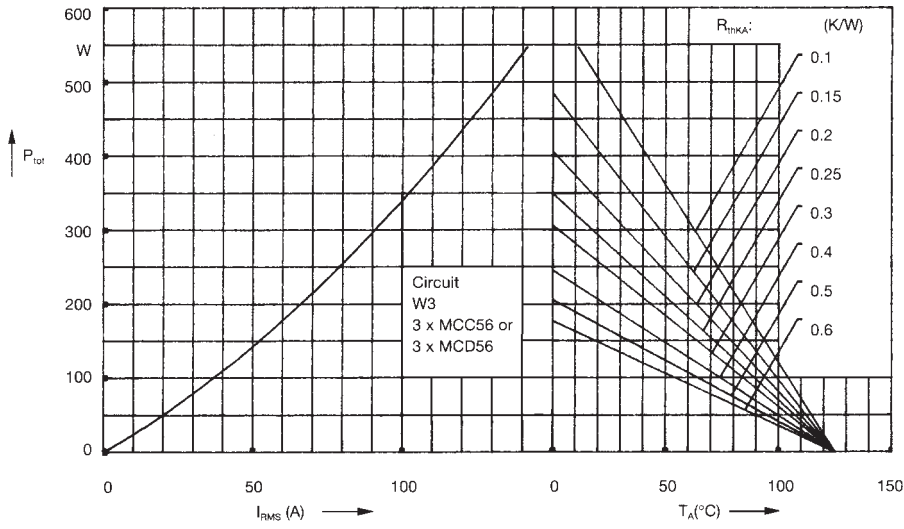

Fig. 7 Three phase AC-controller: Power dissipation versus RMS output current and ambient temperature

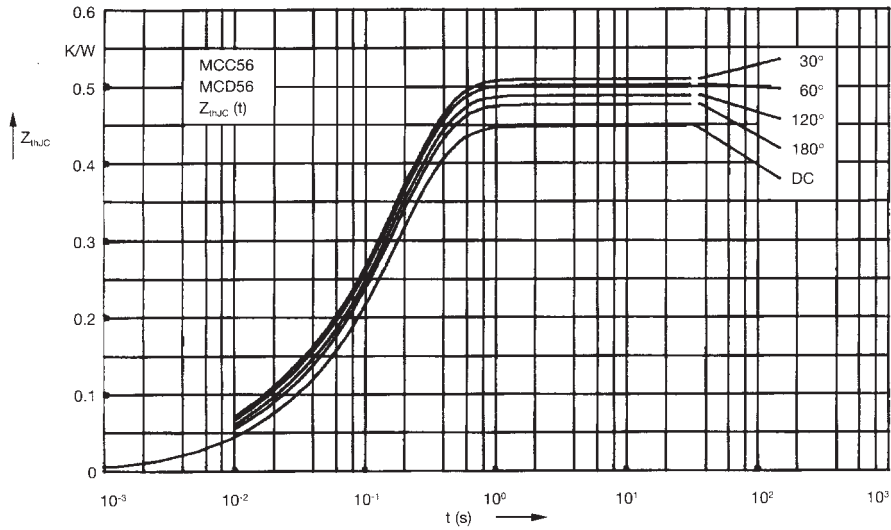

Fig. 8 Transient thermal impedance junction to case (per thyristor or diode)

$R_{thJC}$  for various conduction angles d:

d	$R_{thJC}$ (K/W)
DC	0.45
180°	0.47
120°	0.49
60°	0.505
30°	0.52

Constants for  $Z_{thJC}$  calculation:

i	$R_{thi}$ (K/W)	$t_i$ (s)
1	0.014	0.015
2	0.026	0.0095
3	0.41	0.175

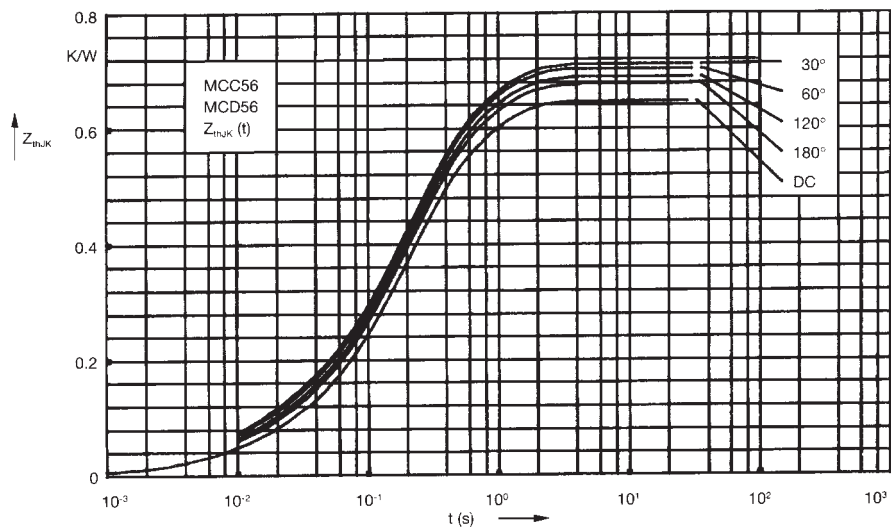

Fig. 9 Transient thermal impedance junction to heatsink (per thyristor or diode)

$R_{thJK}$  for various conduction angles d:

d	$R_{thJK}$ (K/W)
DC	0.65
180°	0.67
120°	0.69
60°	0.705
30°	0.72

Constants for  $Z_{thJK}$  calculation:

i	$R_{thi}$ (K/W)	$t_i$ (s)
1	0.014	0.015
2	0.026	0.0095
3	0.41	0.175
4	0.2	0.67