

## Precision High Slew Rate Operational Amplifier

April 2002

### Features

- This Circuit is Processed in Accordance to MIL-STD-883 and is Fully Conformant Under the Provisions of Paragraph 1.2.1.
- High Slew Rate . . . . . **25V/μs (Min)**  
**30V/μs (Typ)**
- Wide Power Bandwidth . . . . . **350kHz (Min)**
- High Input Impedance . . . . . **25MΩ (Min)**  
**50MΩ (Typ)**
- Low Offset Current . . . . . **25nA (Max)**  
**10nA (Typ)**
- Low Quiescent Current . . . . . **6mA (Max)**
- Fast Settling Time (0.1% of 10V Step) . . . . **330ns (Typ)**
- High Gain Bandwidth Product . . . . . **12MHz (Typ)**
- Internally Compensated For Unity Gain Stability

### Applications

- Data Acquisition Systems
- RF Amplifiers
- Video Amplifiers
- Signal Generators
- Pulse Amplification

### Description

HA-2500/883 is a monolithic operational amplifier which is optimized to deliver excellent slew rate, bandwidth, and settling time specifications. The outstanding dynamic features of this internally compensated device are complemented with low offset voltage and offset current.

This dielectrically isolated amplifier is ideally suited for applications such as data acquisition, RF, video, and pulse conditioning circuits. Guaranteed slew rates of  $\pm 25\text{V}/\mu\text{s}$  minimum make it an excellent component in fast, accurate data acquisition and pulse amplification designs. To insure compliance, all devices are 100% tested for AC performance characteristics over the full temperature limits.

A typical 12MHz gain bandwidth product and 500kHz full power bandwidth make this device well suited to RF and video applications. With guaranteed offset voltages of 5mV plus external offset adjust flexibility and low offset current, this amplifier is particularly useful in signal conditioning designs.

### Ordering Information

PART NUMBER	TEMP. RANGE (°C)	PACKAGE	PKG. NO.
HA2-2500/883	-55 to 125	8 Pin Can	T8.C

### Pinout

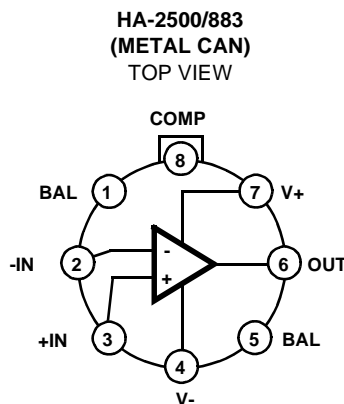

**Absolute Maximum Ratings**

Voltage Between V+ and V- Terminals ..... 40V  
 Differential Input Voltage ..... 15V  
 Voltage at Either Input Terminal ..... V+ to V-  
 Peak Output Current ..... 50mA  
 ESD Rating ..... <2000V

**Operating Conditions**

Temperature Range ..... -55°C to 125°C  
 Supply Voltage ..... ±15V  
 $V_{INCM} \leq 1/2 (V+ - V-)$   
 $R_L \geq 2k\Omega$

CAUTION: Stresses above those listed in "Absolute Maximum Ratings" may cause permanent damage to the device. This is a stress only rating and operation of the device at these or any other conditions above those indicated in the operational sections of this specification is not implied.

NOTE:

1.  $\theta_{JA}$  is measured with the component mounted on a low effective thermal conductivity test board in free air. See Tech Brief TB379 for details.

**Thermal Information**

Thermal Resistance (Typical, Note 1)  $\theta_{JA}$   $\theta_{JC}$   
 Metal Can Package ..... 160°C/W 75°C/W  
 Package Power Dissipation Limit at 75°C for  $T_J \leq 175^\circ\text{C}$   
 Metal Can Package ..... 625mW  
 Package Power Dissipation Derating Factor Above 75°C  
 Metal Can Package ..... 6.3mW/°C  
 Maximum Junction Temperature ..... 175°C  
 Maximum Storage Temperature Range ..... -65°C to 150°C  
 Maximum Lead Temperature (Soldering 10s) ..... 300°C

**TABLE 1. DC ELECTRICAL PERFORMANCE CHARACTERISTICS**

Device Tested at:  $V_{SUPPLY} = \pm 15V$ ,  $R_{SOURCE} = 100\Omega$ ,  $R_{LOAD} = 500k\Omega$ ,  $V_{OUT} = 0V$ , Unless Otherwise Specified.

PARAMETER	SYMBOL	CONDITIONS	GROUP A SUBGROUPS	TEMP (°C)	MIN	MAX	UNITS
Input Offset Voltage	$V_{IO}$	$V_{CM} = 0V$	1	25	-5	5	mV
			2, 3	125, -55	-8	8	mV
Input Bias Current	+ $I_B$	$V_{CM} = 0V$ , + $R_S = 100k\Omega$ , - $R_S = 100\Omega$	1	25	-200	200	nA
			2, 3	125, -55	-400	400	nA
	- $I_B$	$V_{CM} = 0V$ , + $R_S = 100\Omega$ , - $R_S = 100k\Omega$	1	25	-200	200	nA
			2, 3	125, -55	-400	400	nA
Input Offset Current	$I_{IO}$	$V_{CM} = 0V$ , + $R_S = 100k\Omega$ , - $R_S = 100k\Omega$	1	25	-25	25	nA
			2, 3	125, -55	-50	50	nA
Common Mode Range	+CMR	$V+ = 5V$ , $V- = -25V$	1	25	+10	-	V
			2, 3	125, -55	+10	-	V
	-CMR	$V+ = 25V$ , $V- = -5V$	1	25	-	-10	V
			2, 3	125, -55	-	-10	V
Large Signal Voltage Gain	+ $A_{VOL}$	$V_{OUT} = 0V$ and +10V, $R_L = 2k\Omega$	4	25	20	-	kV/V
			5, 6	125, -55	15	-	kV/V
	- $A_{VOL}$	$V_{OUT} = 0V$ and -10V, $R_L = 2k\Omega$	4	25	20	-	kV/V
			5, 6	125, -55	15	-	kV/V
Common Mode Rejection Ratio	+CMRR	$\Delta V_{CM} = +10V$ , $V+ = +5V$ , $V- = -25V$ , $V_{OUT} = -10V$	1	25	80	-	dB
			2, 3	125, -55	80	-	dB
	-CMRR	$\Delta V_{CM} = -10V$ , $V+ = +25V$ , $V- = -5V$ , $V_{OUT} = +10V$	1	25	80	-	dB
			2, 3	125, -55	80	-	dB

## HA-2500/883

**TABLE 1. DC ELECTRICAL PERFORMANCE CHARACTERISTICS (Continued)**

Device Tested at:  $V_{SUPPLY} = \pm 15V$ ,  $R_{SOURCE} = 100\Omega$ ,  $R_{LOAD} = 500k\Omega$ ,  $V_{OUT} = 0V$ , Unless Otherwise Specified.

PARAMETER	SYMBOL	CONDITIONS	GROUP A SUBGROUPS	TEMP (°C)	MIN	MAX	UNITS
Output Voltage Swing	+V <sub>OUT</sub>	R <sub>L</sub> = 2kΩ	4	25	10	-	V
			5, 6	125, -55	10	-	V
	-V <sub>OUT</sub>	R <sub>L</sub> = 2kΩ	4	25	-	-10	V
			5, 6	125, -55	-	-10	V
Output Current	+I <sub>OUT</sub>	V <sub>OUT</sub> = -10V	4	25	10	-	mA
			5, 6	125, -55	7.5	-	mA
	-I <sub>OUT</sub>	V <sub>OUT</sub> = +10V	4	25	-	-10	mA
			5, 6	125, -55	-	-7.5	mA
Quiescent Power Supply Current	+I <sub>CC</sub>	V <sub>OUT</sub> = 0V, I <sub>OUT</sub> = 0mA	1	25	-	6	mA
			2, 3	125, -55	-	6.5	mA
	-I <sub>CC</sub>	V <sub>OUT</sub> = 0V, I <sub>OUT</sub> = 0mA	1	25	-6	-	mA
			2, 3	125, -55	-6.5	-	mA
Power Supply Rejection Ratio	+PSRR	$\Delta V_{SUP} = 10V$ , V+ = +20V, V- = -15V, V+ = +10V, V- = -15V	1	25	80	-	dB
			2, 3	125, -55	80	-	dB
	-PSRR	$\Delta V_{SUP} = 10V$ , V+ = +15V, V- = -20V, V+ = +15V, V- = -10V	1	25	80	-	dB
			2, 3	125, -55	80	-	dB
Offset Voltage Adjustment	+V <sub>IOAdj</sub>	Note 2	1	25	V <sub>IO-1</sub>	-	mV
			2, 3	125, -55	V <sub>IO-1</sub>	-	mV
	-V <sub>IOAdj</sub>	Note 2	1	25	V <sub>IO+1</sub>	-	mV
			2, 3	125, -55	V <sub>IO+1</sub>	-	mV

NOTE:

- Offset adjustment range is [V<sub>IO</sub>(Measured) ±1mV] minimum referred to output. This test is for functionality only to assure adjustment through 0V.

**TABLE 2. ELECTRICAL PERFORMANCE CHARACTERISTICS**

Device Tested at:  $V_{SUPPLY} = \pm 15V$ ,  $R_{SOURCE} = 50\Omega$ ,  $R_{LOAD} = 2k\Omega$ ,  $C_{LOAD} = 50pF$ ,  $A_{VCL} = +1V/V$ , Unless Otherwise Specified.

PARAMETER	SYMBOL	CONDITIONS	GROUP A SUBGROUPS	TEMP (°C)	MIN	MAX	UNITS
Slew Rate	+SR	V <sub>OUT</sub> = -5V to +5V, 25% ≤ +SR ≤ 75%	7	25	25	-	V/μs
			8A, 8B	125, -55	20	-	V/μs
	-SR	V <sub>OUT</sub> = +5V to -5V, 75% ≥ -SR ≥ 25%	7	25	25	-	V/μs
			8A, 8B	125, -55	20	-	V/μs

## HA-2500/883

**TABLE 2. ELECTRICAL PERFORMANCE CHARACTERISTICS (Continued)**

Device Tested at:  $V_{SUPPLY} = \pm 15V$ ,  $R_{SOURCE} = 50\Omega$ ,  $R_{LOAD} = 2k\Omega$ ,  $C_{LOAD} = 50pF$ ,  $A_{VCL} = +1V/V$ , Unless Otherwise Specified.

PARAMETER	SYMBOL	CONDITIONS	GROUP A SUBGROUPS	TEMP (°C)	MIN	MAX	UNITS
Rise and Fall Time	$t_r$	$V_{OUT} = 0$ to $+200mV$ , $10\% \leq t_r \leq 90\%$	7	25	-	50	ns
			8A, 8B	125, -55	-	60	ns
	$t_f$	$V_{OUT} = 0$ to $-200mV$ , $10\% \leq t_f \leq 90\%$	7	25	-	50	ns
			8A, 8B	125, -55	-	60	ns
Overshoot	+OS	$V_{OUT} = 0$ to $+200mV$	7	25	-	40	%
			8A, 8B	125, -55	-	50	%
	-OS	$V_{OUT} = 0$ to $-200mV$	7	25	-	40	%
			8A, 8B	125, -55	-	50	%

**TABLE 3. ELECTRICAL PERFORMANCE CHARACTERISTICS**

Device Characterized at:  $V_{SUPPLY} = \pm 15V$ ,  $R_{LOAD} = 2k\Omega$ ,  $C_{LOAD} = 50pF$ , Unless Otherwise Specified.

PARAMETER	SYMBOL	CONDITIONS	NOTES	TEMP (°C)	MIN	MAX	UNITS
Differential Input Resistance	$R_{IN}$	$V_{CM} = 0V$	3	25	25	-	$M\Omega$
Full Power Bandwidth	FPBW	$V_{PEAK} = 10V$	3, 4	25	350	-	kHz
Minimum Closed Loop Stable Gain	CLSG	$R_L = 2k\Omega$ , $C_L = 50pF$	3	-55 to 125	1	-	V/V
Quiescent Power Consumption	PC	$V_{OUT} = 0V$ , $I_{OUT} = 0mA$	3, 5	-55 to 125	-	195	mW

**NOTES:**

3. Parameters listed in Table 3 are controlled via design or process parameters and are not directly tested at final production. These parameters are lab characterized upon initial design release, or upon design changes. These parameters are guaranteed by characterization based upon data from multiple production runs which reflect lot to lot and within lot variation.
4. Full Power Bandwidth guarantee based on Slew Rate measurement using  $FPBW = \text{Slew Rate}/(2\pi V_{PEAK})$ .
5. Quiescent Power Consumption based upon Quiescent Supply Current test maximum. (No load on outputs.)

**TABLE 4. ELECTRICAL TEST REQUIREMENTS**

MIL-STD-883 TEST REQUIREMENTS	SUBGROUPS (SEE TABLES 1 AND 2)
Interim Electrical Parameters (Pre Burn-In)	1
Final Electrical Test Parameters	1 (Note 6), 2, 3, 4, 5, 6, 7, 8A, 8B
Group A Test Requirements	1, 2, 3, 4, 5, 6, 7, 8A, 8B
Groups C and D Endpoints	1

**NOTE:**

6. PDA applies to Subgroup 1 only.

# HA-2500/883

## Die Characteristics

### DIE DIMENSIONS:

57 x 65 x 19 milss  
1450 x 1650 x 483µm

### METALLIZATION:

Type: Al, 1% Cu  
Thickness: 16kÅ ± 2kÅ

### GLASSIVATION:

Type: Nitride (Si3N4) over Silox (SiO2, 5% Phos.)  
Silox Thickness: 12kÅ ± 2kÅ  
Nitride Thickness: 3.5kÅ ± 1.5kÅ

### WORST CASE CURRENT DENSITY:

$0.3 \times 10^5 \text{ A/cm}^2$

### SUBSTRATE POTENTIAL (Powered Up):

Unbiased

### TRANSISTOR COUNT:

HA-2500/883: 40

### PROCESS: Bipolar Dielectric Isolation

## Metallization Mask Layout

HA-2500/883

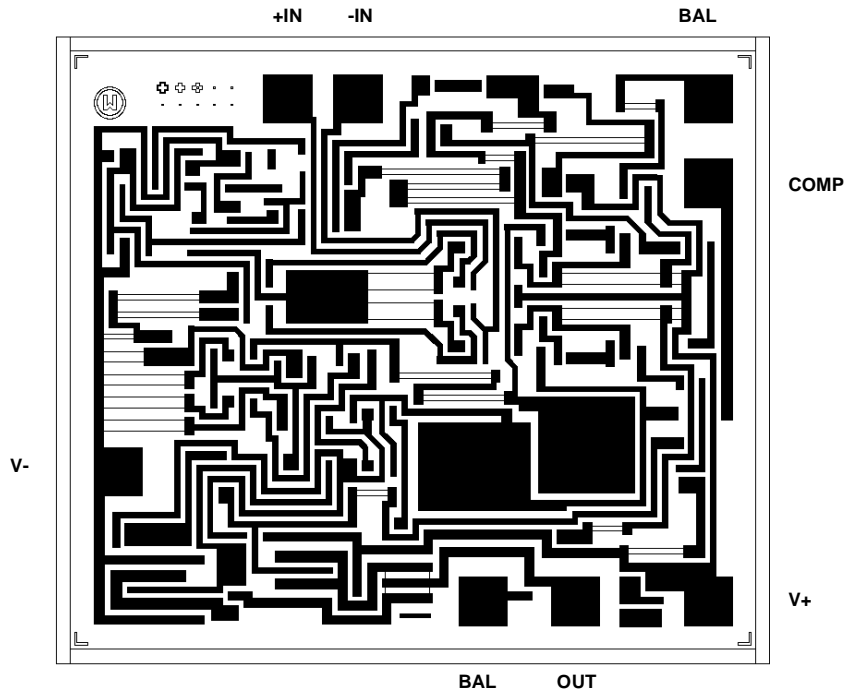

**Burn-In Circuits**

HA2-2500/883 METAL CAN

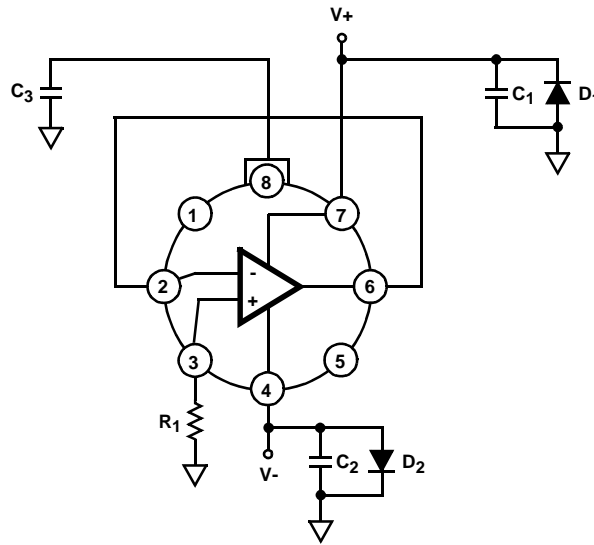

NOTES:

$R_1 = 1M\Omega, \pm 5\%, 1/4W$  (Min)

$C_1 = C_2 = 0.01\mu F$ /Socket (Min) or  $0.1\mu F$ /Row (Min)

$C_3 = 0.01\mu F$ /Socket (10%)

$D_1 = D_2 = 1N4002$  or Equivalent/Board

$|(V+) - (V-)| = 30V$

**Metal Can Packages (Can)**

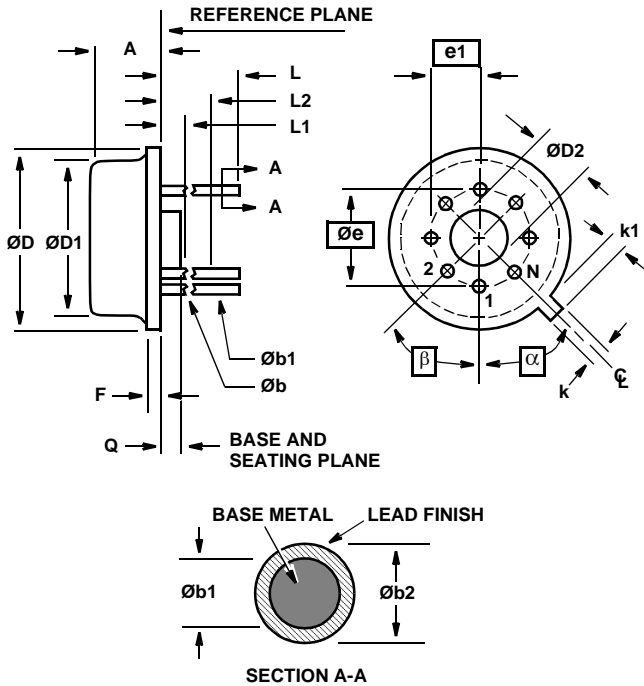

**NOTES:**

1. (All leads)  $\varnothing b$  applies between L1 and L2.  $\varnothing b1$  applies between L2 and 0.500 from the reference plane. Diameter is uncontrolled in L1 and beyond 0.500 from the reference plane.
2. Measured from maximum diameter of the product.
3.  $\alpha$  is the basic spacing from the centerline of the tab to terminal 1 and  $\beta$  is the basic spacing of each lead or lead position (N - 1 places) from  $\alpha$ , looking at the bottom of the package.
4. N is the maximum number of terminal positions.
5. Dimensioning and tolerancing per ANSI Y14.5M - 1982.
6. Controlling dimension: INCH.

**T8.C MIL-STD-1835 MACY1-X8 (A1)  
8 LEAD METAL CAN PACKAGE**

SYMBOL	INCHES		MILLIMETERS		NOTES
	MIN	MAX	MIN	MAX	
A	0.165	0.185	4.19	4.70	-
$\varnothing b$	0.016	0.019	0.41	0.48	1
$\varnothing b1$	0.016	0.021	0.41	0.53	1
$\varnothing b2$	0.016	0.024	0.41	0.61	-
$\varnothing D$	0.335	0.375	8.51	9.40	-
$\varnothing D1$	0.305	0.335	7.75	8.51	-
$\varnothing D2$	0.110	0.160	2.79	4.06	-
e	0.200 BSC		5.08 BSC		-
e1	0.100 BSC		2.54 BSC		-
F	-	0.040	-	1.02	-
k	0.027	0.034	0.69	0.86	-
k1	0.027	0.045	0.69	1.14	2
L	0.500	0.750	12.70	19.05	1
L1	-	0.050	-	1.27	1
L2	0.250	-	6.35	-	1
Q	0.010	0.045	0.25	1.14	-
$\alpha$	45° BSC		45° BSC		3
$\beta$	45° BSC		45° BSC		3
N	8		8		4

Rev. 0 5/18/94

All Intersil U.S. products are manufactured, assembled and tested utilizing ISO9000 quality systems. Intersil Corporation's quality certifications can be viewed at [www.intersil.com/design/quality](http://www.intersil.com/design/quality)

*Intersil products are sold by description only. Intersil Corporation reserves the right to make changes in circuit design, software and/or specifications at any time without notice. Accordingly, the reader is cautioned to verify that data sheets are current before placing orders. Information furnished by Intersil is believed to be accurate and reliable. However, no responsibility is assumed by Intersil or its subsidiaries for its use; nor for any infringements of patents or other rights of third parties which may result from its use. No license is granted by implication or otherwise under any patent or patent rights of Intersil or its subsidiaries.*

For information regarding Intersil Corporation and its products, see [www.intersil.com](http://www.intersil.com)

**Sales Office Headquarters**

**NORTH AMERICA**  
Intersil Corporation  
7585 Irvine Center Drive  
Suite 100  
Irvine, CA 92618  
TEL: (949) 341-7000  
FAX: (949) 341-7123

Intersil Corporation  
2401 Palm Bay Rd.  
Palm Bay, FL 32905  
TEL: (321) 724-7000  
FAX: (321) 724-7946

**EUROPE**  
Intersil Europe Sarl  
Ave. William Grasse, 3  
1006 Lausanne  
Switzerland  
TEL: +41 21 6140560  
FAX: +41 21 6140579

**ASIA**  
Intersil Corporation  
Unit 1804 18/F Guangdong Water Building  
83 Austin Road  
TST, Kowloon Hong Kong  
TEL: +852 2723 6339  
FAX: +852 2730 1433