

FEATURES

- Normally Open and Close, Single Pole Single Throw
- Control 400 VAC or DC Voltage
- Switch 130 mA Loads
- LED Control Current, 2mA
- Low ON-Resistance
- dv/dt , >500 V/ms
- Isolation Test Voltage, 3750 VAC_{RMS}
- UL, CSA, FCC compatible
- Applications
 - Telecommunications
 - Telecom Switching
 - Tip/Ring Circuits
 - Modem Switching (Laptop, Notebook, Pocket Size)
 - Hookswitch
 - Dial Pulsing
 - Ground Start
 - Ringer Injection
 - Instrumentation
 - Multiplexers
 - Data Acquisition
 - Electronic Switching
 - I/O Subsystems
 - Meters (Watt-Hour, Water, Gas)
 - Medical Equipment
 - High Voltage Test Equipment
 - TRIAC Driver
 - Motor Control
 - Security
 - Aerospace
 - Industrial Controls

DESCRIPTION

The LH1502 is a single pole single throw (SPST), normally open and close. The relay can control AC or DC loads currents up to 130 mA, with a supply voltage up to 400 V. The device is packaged in a 8 pin SMD and dual-in line package. Those package offer an insulation dielectric withstand of 3750 VAC_{RMS}.

The coupler consists of a AlGaAs LED that is optically coupled to a dielectrically isolated photodiode array which drives two series connected high voltage MOS transistors.

● Turn on/Turn off time



● Operate/Reverse time

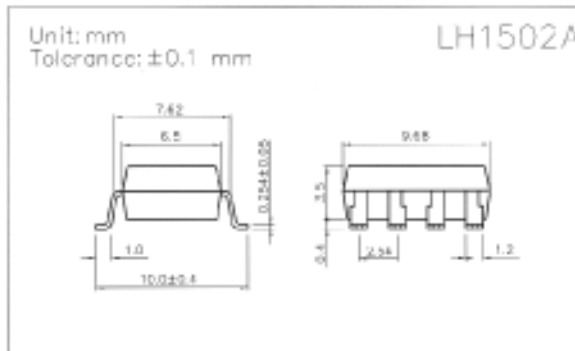
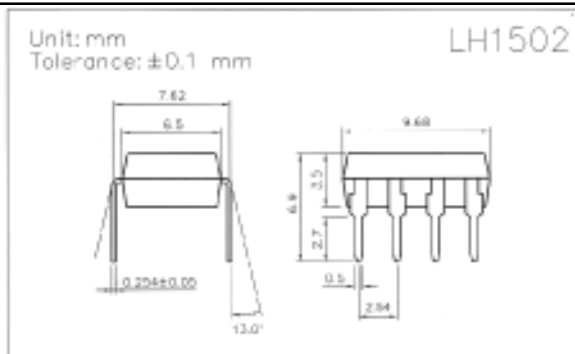

Absolute Maximum Ratings (T_A = 25°C)

Emitter (Input)

Reverse Voltage.....	5.0V
Continuous Forward Current.....	50mA
Peak Forward Current (1s).....	1A
Power Dissipation.....	100mW
Derate Linearly from 25°C.....	1.3mW/°C

Detector (Output)

Output Breakdown Voltage.....	±400V
Continuous Load Current.....	±130mA
Power Dissipation.....	500mW

General Characteristics

Isolation Test Voltage.....	3750VAC _{RMS}
Isolation Resistance	
$V_{ID} = 500V, T_A = 25°C$	$\geq 10^{10} \Omega$
Total Power Dissipation.....	550mW
Derate Linearly from 25°C.....	2.5mW/°C
Storage Temperature Range.....	-40 to +150°C
Operating Temperature Range.....	-40 to +85°C
Junction Temperature.....	100°C
Soldering Temperature, 2mm from case, 10 sec... ..	260°C

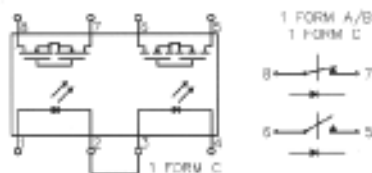

Characteristics

(T_A = 25°C)

Description	Symbol	Min.	Typ.	Max.	Unit	Test Condition
Emitter (Input)						
Forward Voltage	V _F		1.8	2.0	V	I _F = 10 mA
Operation Input Current	I _{FON(N.O)} I _{FOFF(N.C)}			5	mA	V _L = ± 20V, I _L = 100 mA (N.O) V _L = ± 20V, I _L = <5 μA (N.C) t = 10 ms
Recovery Input Current	I _{POFF(N.O)} I _{PON(N.C)}	0.2			mA	V _L = ± 20V, I _L = <5 μA (N.O) V _L = ± 20V, I _L = 100 mA (N.C) t = 10 ms
Detector (output) normally open						
Output Breakdown Voltage	V _B	400			V	I _B = 50 μA
Output Off-State Leakage	I _{T(OFF)}		0.2	1	μA	V _T = 100 V, I _F = 0 mA
I/O Capacitance	C _{ISO}		6		pF	I _F = 0, f = 1 MHz
ON Resistance	R _{ON}		20	25	Ω	I _L = 100 mA, I _F = 10 mA
Turn-on Time	T _{ON}		0.3	1.0	ms	I _F = 10 mA, V _L = ± 20 V
Turn-off Time	T _{OFF}		0.7	1.5	ms	t = 10 ms, I _L = ± 100 mA

Detector (output) normally close						
Output Breakdown Voltage	V _B	400			V	I _B = 50 μA
Output Off-State Leakage	I _{T(OFF)}		0.2	1	μA	V _T = 100 V, I _F = 10 mA
I/O Capacitance	C _{ISO}		6		pF	I _F = 0, f = 1 MHz
ON Resistance	R _{ON}		40	50	Ω	I _L = 100 mA, I _F = 0 mA
Reverse (ON) Time	T _{ON}		0.6	1.5	ms	I _F = 10 mA, V _L = ± 20 V
Operate (OFF) Time	T _{OFF}		0.3	1.0	ms	t = 10 ms, I _L = ± 100 mA

Photo Mos Relay Schematic and Wiring Diagrams					
Type	Schematic	Output configuration	Load	Con-nection	Wiring diagram
LH1502 & LH1502A		1a1b	AC/DC	-	<p>(1) Two independent 1 Form A & 1 Form B use</p> <p>(2) 1 Form A 1 Form B use</p>