

SMD

Rated voltage 42 V~/80V-
Rated inductance 11 to 100 μ H
Rated current 150 to 300 mA

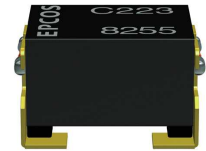

Construction

- Current-compensated double choke with ferrite I core
- Bifilar winding (B82789C0...)
- Sector winding (B82789S0...)

Features

- Suitable for reflow soldering
- For gold-plated terminals conductive adhesion possible

Function

- B82789C0:
Suppression of asymmetrical interference coupled in on lines whereas data signals up to some MHz can pass unaffectedly
- B82789S0:
Suppression of asymmetrical (by L_R) and symmetrical interference (by L_S) coupled in on lines. The high-frequency portions of the symmetrical data signal are decreased so far that EMC problems can be significantly reduced

Applications

- Automotive applications, e.g. CAN-Bus
- Industrial automation
- Telecommunications

Terminals

- Two versions: Gold plated and lead free tinned

Marking

Marking on component:
Manufacturer, bifilar or sector winding (coded), L value (in nH),
date of manufacture (coded)

Minimum data on reel:

Manufacturer, part number, ordering code, L value (in nH),
quantity, date of packing

Delivery mode

12-mm blister tape, reel packing (330-mm \varnothing reel), packing unit: 2500 pcs

Taping to IEC 60286-3. For details on taping and packing refer to data book
"Chokes and Inductors", page 302



General technical data

Rated voltage V_R	42 V~ (50/60 Hz) 80 V-
Rated current I_R	Referred to 50 Hz and 110°C ambient temperature
Rated inductance L_R	Measured with HP 4284A at 100kHz, 0,1mA
Inductance tolerance	-30/ +50%
Stray inductance L_S	Measured with HP 4284A at 100 kHz and 5 mA
Inductance decrease $\Delta L/L$	<10% at dc magnetic bias with I_R
DC-resistance R_{max}	Measured at 20 °C ambient temperature
Solderability	(235 ± 3) °C , (2 ± 0,3) s wetting of soldering area ≥ 95 % in accordance with IEC 60068-2-58
Test voltage	250V-, 2s
Climatic category	55/150/56 (-55°C/+150°C/ 56 days damp heat test) in accordance with DIN EN 60068-1
Weight	approx. 0,16 g

L_R μH	L_S , typ μH	I_R mA	R_{max} mΩ	Ordering code	
				gold-plated terminals	tinned terminals
11	0,06	300	250	B82789C0113H001	B82789C0113H002
22	0,1	250	580	B82789C0223H001	B82789C0223H002
22	3,0	250	580	B82789S0223H001	B82789S0223H002
51	0,10	250	550	B82789C0513H001	B82789C0513H002
100	0,25	150	1500	B82789C0104H001	B82789C0104H002

SMD

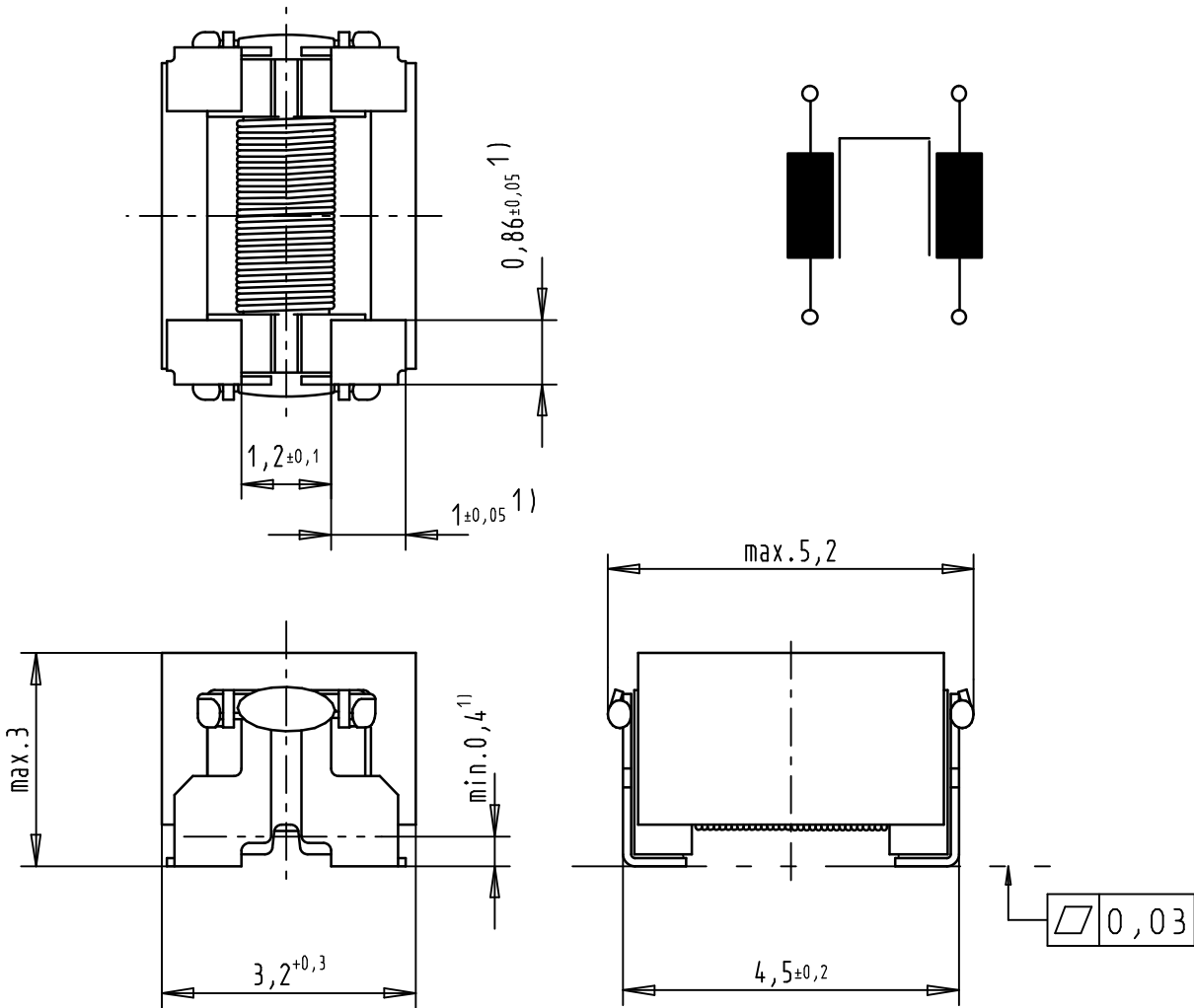
Dimensional drawing



Layout recommendation

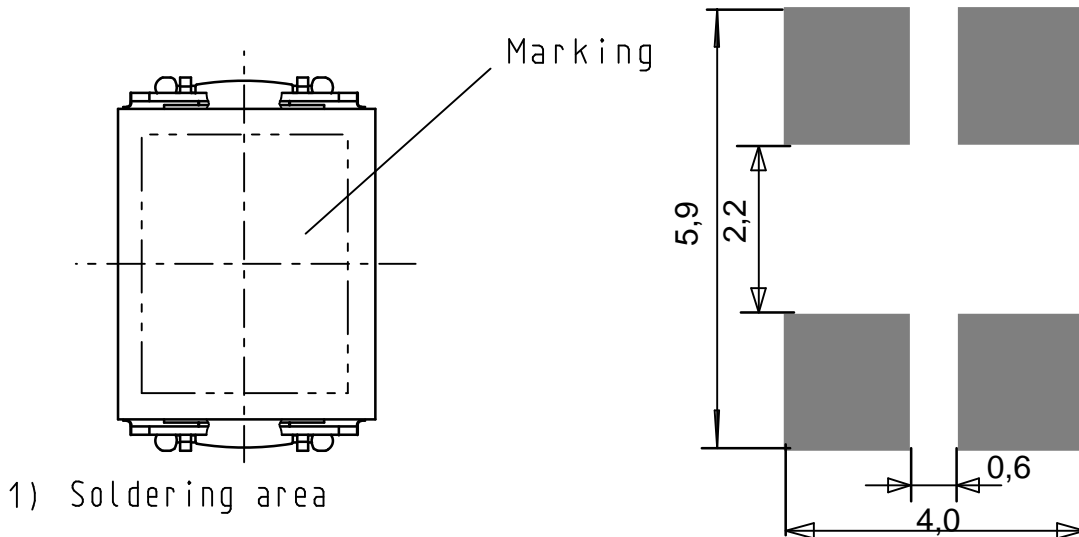

SMD

Current derating I_{OP}/I_R
 versus ambient Temperature $T_A = 110^\circ\text{C}$

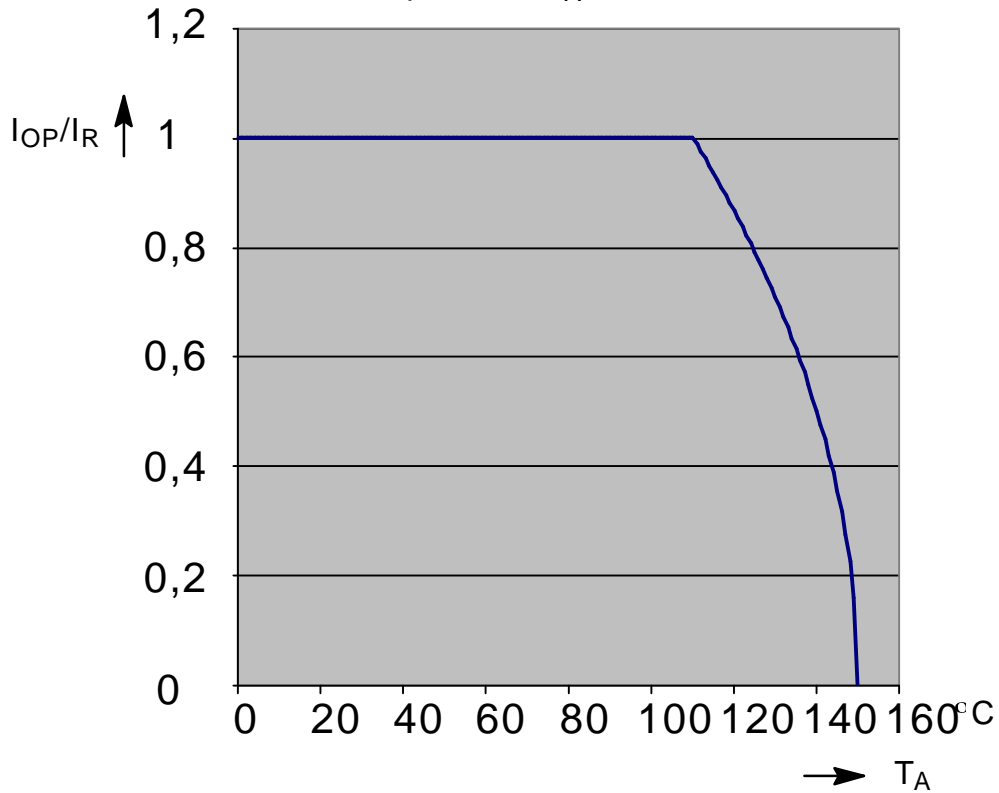

SMD

Insertion loss a_e (typical values at $Z = 50\Omega$)

— — — — — asymmetrical, both lines in parallel (common mode)

— — — — —

symmetrical, both lines in series (differential mode)

B82789C0113H00*

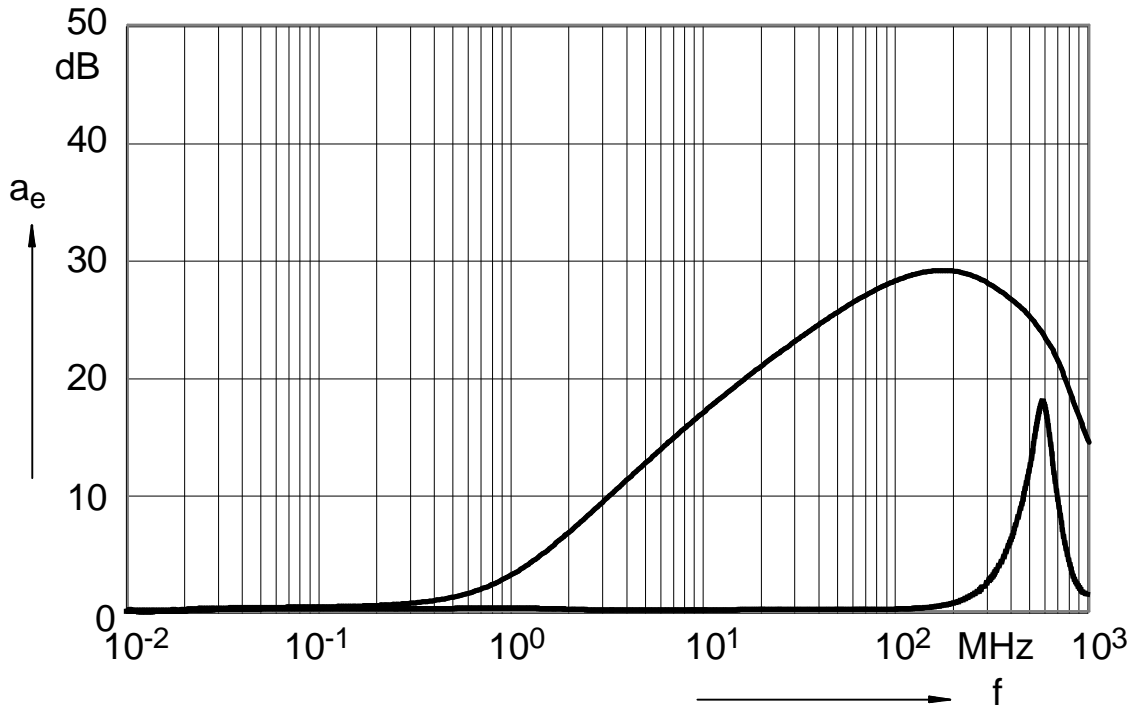

B82789C0223H00*

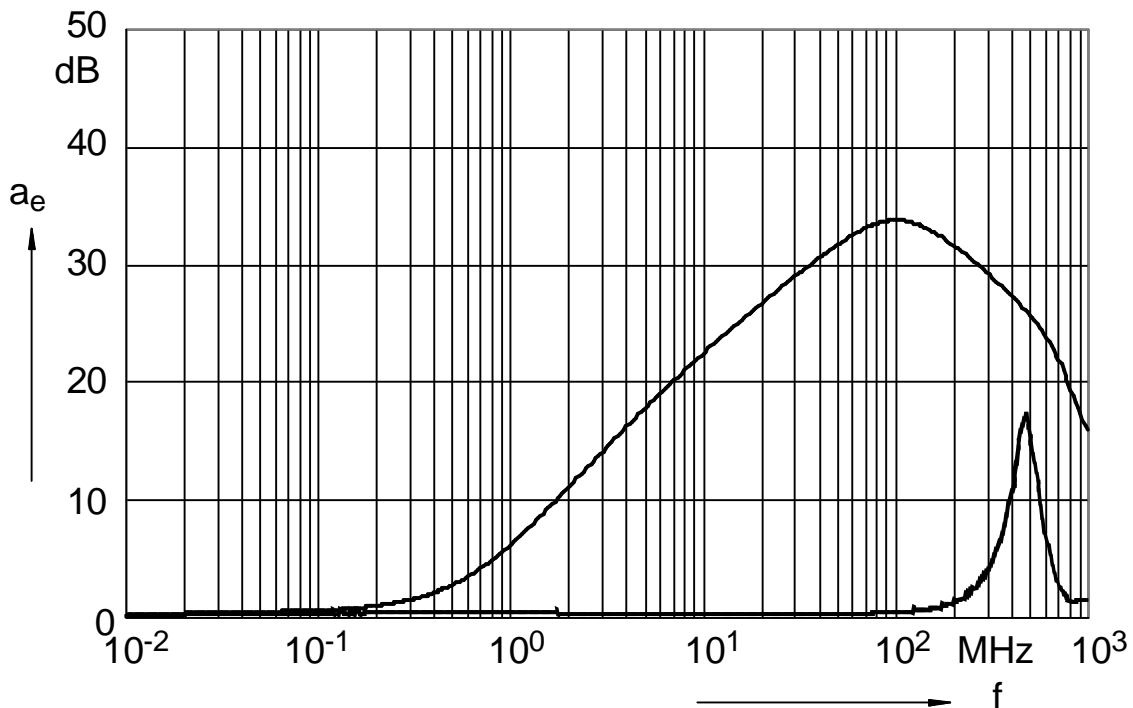



Insertion loss α_e (typical values at $Z = 50\Omega$)

— — — — — asymmetrical, both lines in parallel (common mode)

— — — — —

symmetrical, both lines in series (differential mode)

B82789C0513H00*

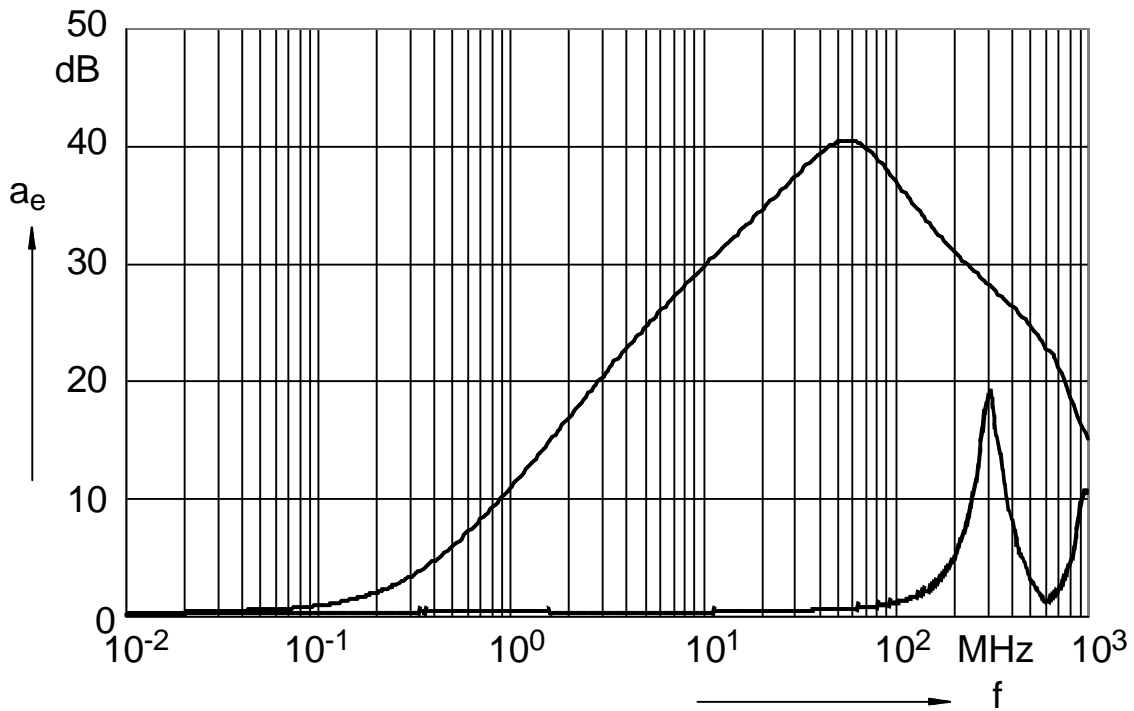

B82789C0104H00*

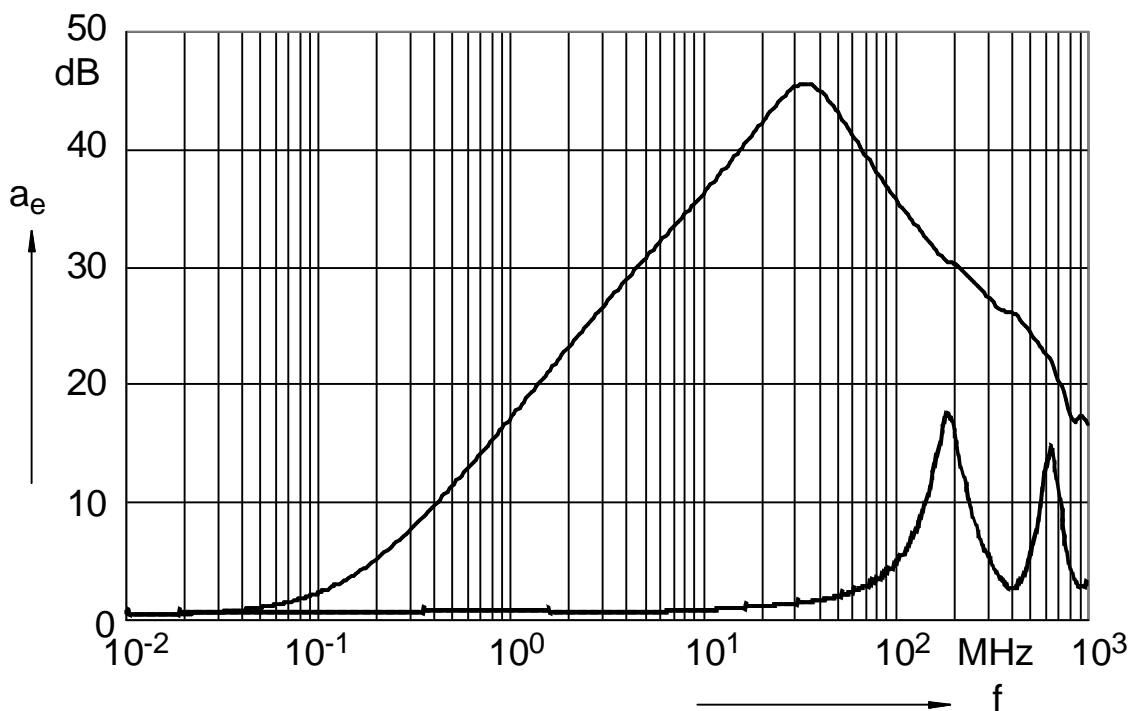

SMD

Insertion loss α_e (typical values at $Z = 50\Omega$)

— — — — — asymmetrical, both lines in parallel (common mode)

— — — — —

symmetrical, both lines in series (differential mode)

B82789S0223H00*

