

### Features

- Low Forward Voltage Drop
- Guard Ring Construction for Transient Protection
- Negligible Reverse Recovery Time
- Very Low Reverse Capacitance

### Mechanical Data

- Case: SOD-123, Plastic
- Case material - UL Flammability Rating Classification 94V-0
- Moisture sensitivity: Level 1 per J-STD-020A
- Polarity: Cathode Band
- Leads: Solderable per MIL-STD-202, Method 208
- Marking: Date Code & Type Code, See Page 2
- Type Codes: SD101AW S1 or SK  
SD101BW S2 or SK  
SD101CW S3 or SK
- Weight: 0.01 grams (approx.)
- Ordering Information: See Page 2

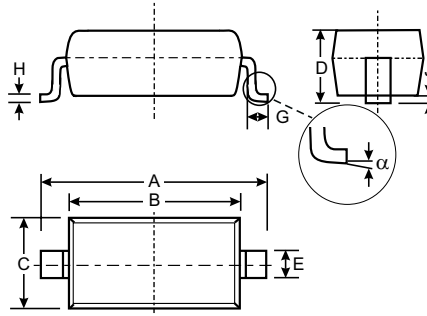

SOD-123		
Dim	Min	Max
A	3.55	3.85
B	2.55	2.85
C	1.40	1.70
D	—	1.35
E	0.55 Typical	
G	0.25	—
H	0.11 Typical	
J	—	0.10
$\alpha$	0°	8°
All Dimensions in mm		

### Maximum Ratings @ $T_A = 25^\circ\text{C}$ unless otherwise specified

Characteristic	Symbol	SD101AW	SD101BW	SD101CW	Unit
Peak Repetitive Reverse Voltage	$V_{RRM}$				
Working Peak Reverse Voltage	$V_{RWM}$	60	50	40	V
DC Blocking Voltage	$V_R$				
RMS Reverse Voltage	$V_{R(RMS)}$	42	35	28	V
Forward Continuous Current (Note 1)	$I_{FM}$		15		mA
Non-Repetitive Peak Forward Surge Current @ $t \leq 1.0\text{s}$ @ $t = 10\mu\text{s}$	$I_{FSM}$		50 2.0		mA A
Power Dissipation (Note 1)	$P_d$		400		mW
Thermal Resistance, Junction to Ambient Air (Note 1)	$R_{\theta JA}$		300		$^\circ\text{C/W}$
Operating and Storage Temperature Range	$T_j, T_{STG}$		-65 to +125		$^\circ\text{C}$

### Electrical Characteristics @ $T_A = 25^\circ\text{C}$ unless otherwise specified

Characteristic	Symbol	Min	Max	Unit	Test Condition
Reverse Breakdown Voltage (Note 2)	SD101AW SD101BW SD101CW $V_{(BR)R}$	60 50 40	—	V	$I_R = 10\mu\text{A}$ $I_R = 10\mu\text{A}$ $I_R = 10\mu\text{A}$
Forward Voltage Drop (Note 2)	SD101AW SD101BW SD101CW SD101AW SD101BW SD101CW $V_{FM}$	—	0.41 0.40 0.39 1.00 0.95 0.90	V	$I_F = 1.0\text{mA}$ $I_F = 1.0\text{mA}$ $I_F = 1.0\text{mA}$ $I_F = 15\text{mA}$ $I_F = 15\text{mA}$ $I_F = 15\text{mA}$
Peak Reverse Current (Note 2)	SD101AW SD101BW SD101CW $I_{RM}$	—	200	nA	$V_R = 50\text{V}$ $V_R = 40\text{V}$ $V_R = 30\text{V}$
Total Capacitance	SD101AW SD101BW SD101CW $C_T$	—	2.0 2.1 2.2	pF	$V_R = 0\text{V}, f = 1.0\text{MHz}$
Reverse Recovery Time	$t_{rr}$	—	1.0	ns	$I_F = I_R = 5.0\text{mA}$ , $I_{rr} = 0.1 \times I_R, R_L = 100\Omega$

Notes: 1. Part mounted on FR-4 board with recommended pad layout, which can be found on our website at <http://www.diodes.com/datasheets/ap02001.pdf>.  
2. Short duration test pulse used to minimize self-heating effect.

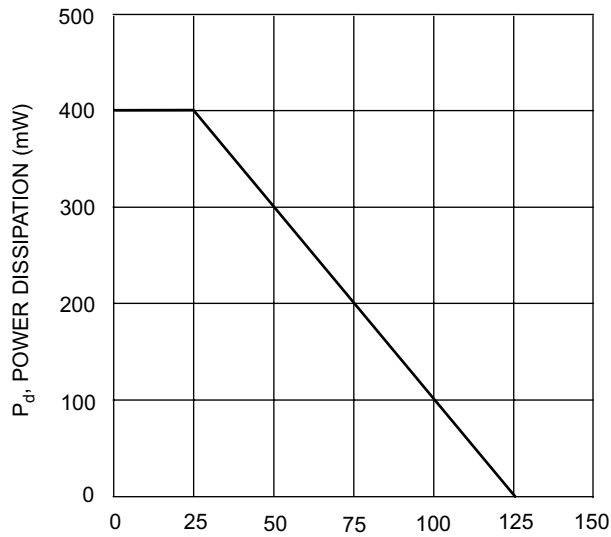

$T_A$ , AMBIENT TEMPERATURE (°C)  
Fig. 1 Power Derating Curve

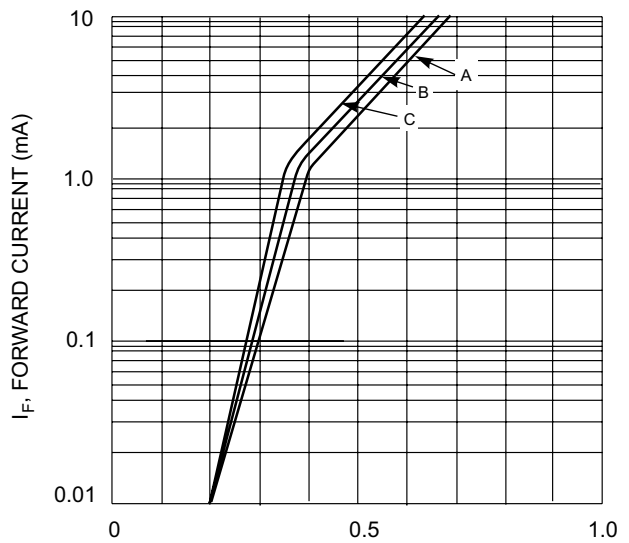

$V_F$ , FORWARD VOLTAGE (V)  
Fig. 2 Typical Forward Characteristic

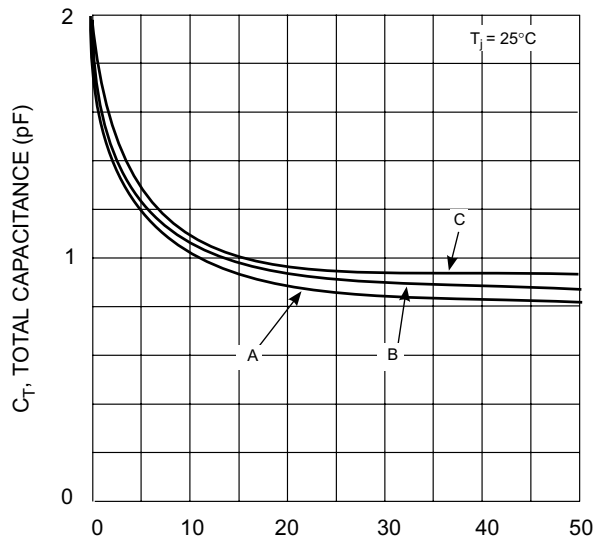

$V_R$ , REVERSE VOLTAGE (V)  
Fig. 3 Typ. Total Capacitance vs Reverse Voltage

## Ordering Information (Note 3)

Device	Packaging	Shipping
SD101AW-7	SOD-123	3000/Tape and Reel
SD101BW-7	SOD-123	3000/Tape and Reel
SD101CW-7	SOD-123	3000/Tape and Reel

Note: 3. For Packaging Details, go to our website at <http://www.diodes.com/datasheets/ap02007.pdf>.

## Marking Information

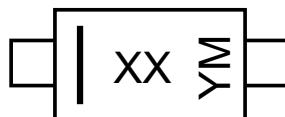

XX = Product Type Marking Code  
YM = Date Code Marking  
Y = Year (ex: N = 2002)  
M = Month (ex: 9 = September)

Date Code Key

Year	1998	1999	2000	2001	2002	2003	2004	2005
Code	J	K	L	M	N	P	R	S

Month	Jan	Feb	March	Apr	May	Jun	Jul	Aug	Sep	Oct	Nov	Dec
Code	1	2	3	4	5	6	7	8	9	O	N	D